

EE523

HW#5 - Due Thursday 3/12/09

1. P 4.27, text
2. P 4.29, text. (In part b, the attenuation is $20\log_{10}|T|$. Plot this as a function of Z_L / Z_o . Use Matlab or MathCad to plot.)
3. P 4.30, text. First, use signal flow graph decomposition to compute the power ratios. Repeat using Mason's rule.
4. You are to design a 3 dB T-junction power divider that is matched at all three ports to 50 ohms. at 10 GHz. Assume ideal TEM transmission lines with an $\epsilon_r = 1.0$ (air).

5. You are to validate your design in problem 4 using the *Agilent ADS (Advanced Design System)* software. This software is available to you in the computer lab on the 2nd floor of the Oliver Raymond Building. The tutorials for the software can be found on the course web page. In this first problem, you should using the physical transmission line models. This is under the "TLines-Ideal" pull down menu. Use the "physical Transmission line" mode (TLINP) for your transmission line sections. Double click on the TLINP object to change its parameters, such as Zo and length. Note that $K = \epsilon_r$. Also, you can set the attenuation parameters to be 0 or very small for the ideal line. Also, assume that the port 1 has a feed line that is 5 mm in length. Next, to simulate the S-parameters, in the pull-down menu, select "Simulation-S_Param".

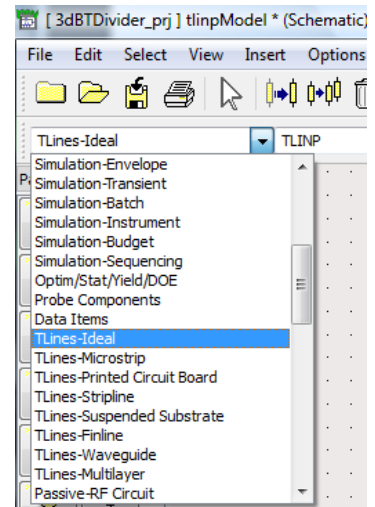

Then choose **S P** and put it on the bench top. You will also need to put three "Terms" on your bench top, 1 for each port. Each of these should be grounded. Your final bench top should look like this:

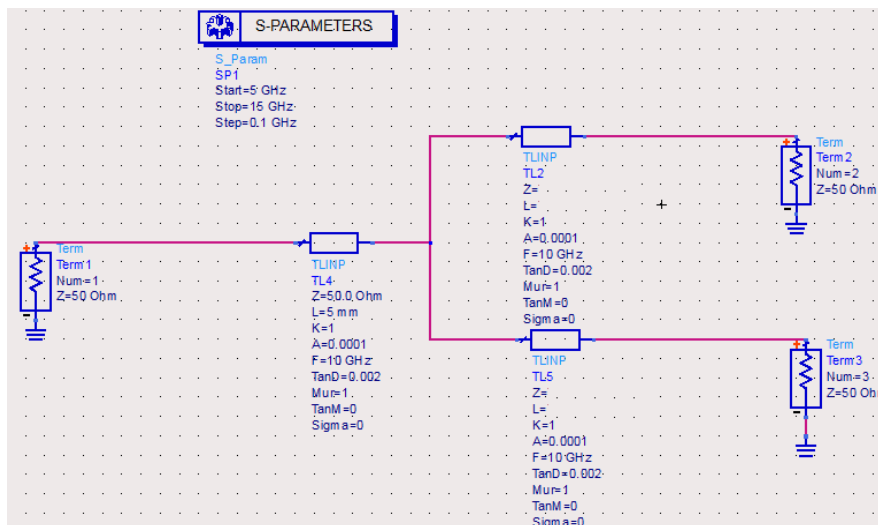



Simulate the circuit. The result display window will come up. Using 2D rectangular plots plot in dB $|S_{11}|, |S_{12}|, |S_{13}|, |S_{23}|, |S_{22}|$. Don't put them all on 1 graph. Group them together so that the different curves, and their ranges make sense.