

Structural Axial, Shear and Bending Moments

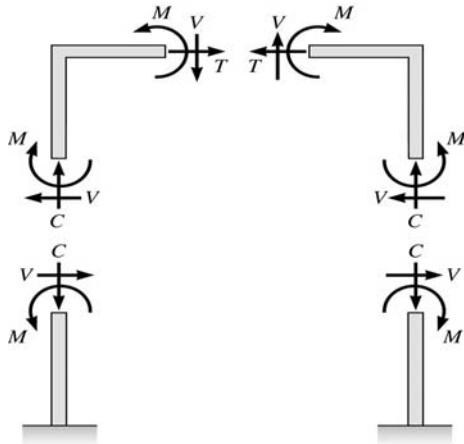

Positive Internal Forces Acting on a Portal Frame

1

Recall from mechanics of materials that the internal forces **P** (generic axial), **V** (shear) and **M** (moment) represent resultants of the stress distribution acting on the cross section of the beam.

Internal Axial Force (P) \equiv equal in magnitude but opposite in direction to the algebraic sum (resultant) of the components in the direction parallel to the axis of the beam of all external loads and support reactions acting on either side of the section being considered.

T \equiv Tension
C \equiv Compression

2

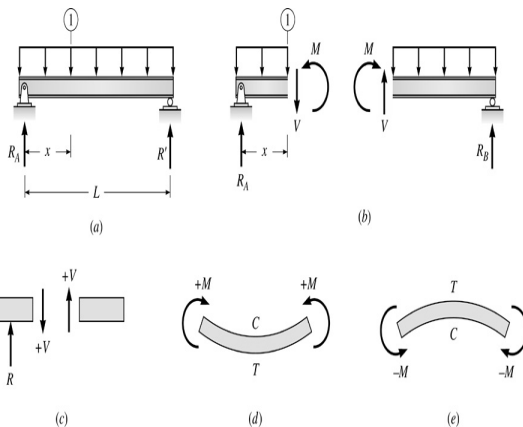

Beam Sign Convention for Shear and Moment

3

Internal Shear Force (V) \equiv equal in magnitude but opposite in direction to the algebraic sum (resultant) of the components in the direction perpendicular to the axis of the beam of all external loads and support reactions acting on either side of the section being considered.

Internal Bending Moment (M) \equiv equal in magnitude but opposite in direction to the algebraic sum of the moments about (the centroid of the cross section of the beam) the section of all external loads and support reactions acting on either side of the section being considered.

4

Positive Sign Conventions:

Tension axial force on the section

Shears that produces clockwise moments

Bending moments that produce compression in the top fibers and tension in the bottom fibers of the beam

5

Shear and bending moment diagrams depict the variation of these quantities along the length of the member.

Proceeding from one end of the member to the other, sections are passed. After **each successive change in loading** along the length of the member, a **FBD (Free Body Diagram)** is drawn to determine the equations expressing the shear and bending moment in terms of the distance from a convenient origin.

Plotting these equations produces the shear and bending moment diagrams.

6

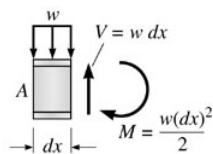
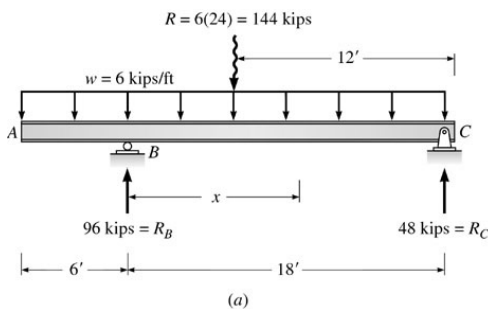

(b)

V and M are in the opposite directions of the positive beam sign convention

7

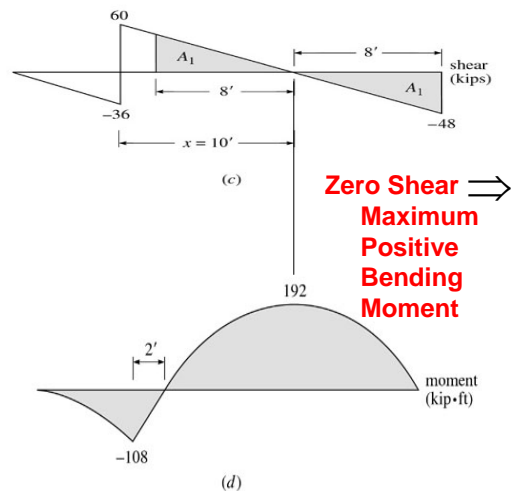

Zero Shear \Rightarrow Maximum Positive Bending Moment

Shear and Bending Moment Diagrams

8

Principle of Superposition

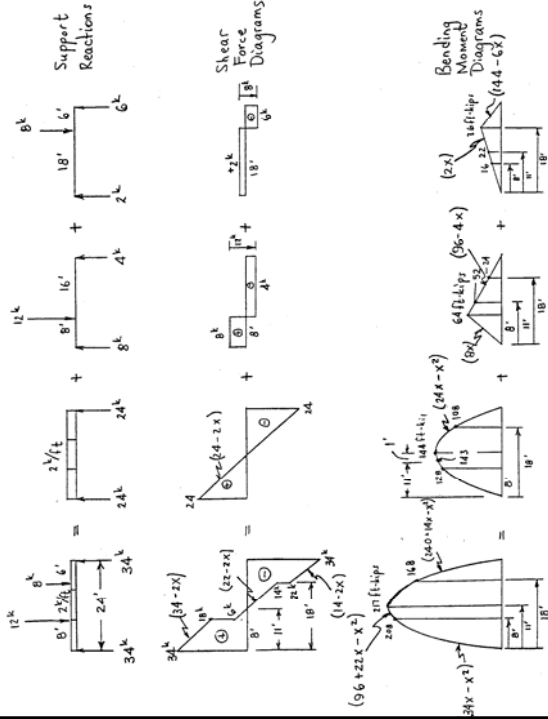

Example Problem Shear and Moment Diagrams

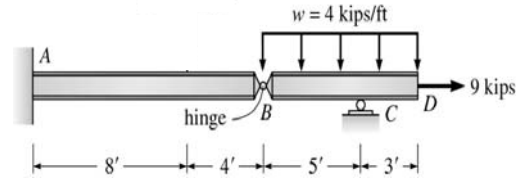

Calculate and draw the shear force and bending moment equations for the given structure.

10

Sketching the Deflected Shape of a Beam or Frame

Qualitative Deflected Shape

(elastic curve) ≡ a rough (usually exaggerated) sketch of the neutral surface of the structure in the deformed position under the action of a given loading condition.

Such sketches provide valuable insights into the behavior of structures.

11

Following our positive beam sign convention, a **positive bending moment bends a beam concave upward** (or toward the positive y direction), whereas a **negative bending moment bends a beam concave downward** (or towards the negative y direction).

Positive Bending

Negative Bending

12

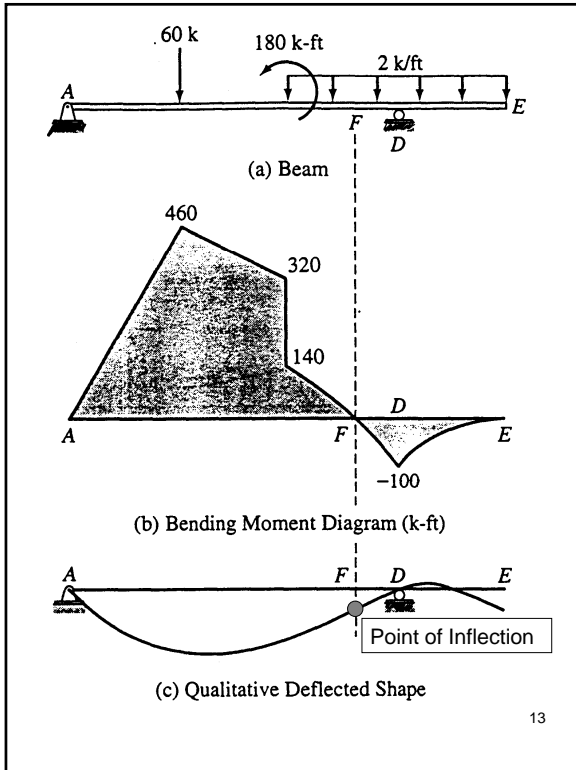

An accurate sketch must satisfy the following rules:

- The curvature must be consistent with the moment curve.
- The deflected shape must satisfy the boundary constraints.
- The original angle at a rigid joint must be preserved.
- The length of the deformed member is the same as the original length of the unloaded member.

14

- The horizontal projection of a beam or the vertical projection of a column is equal to the original length of the member.
- Axial deformations, which are trivial compared to bending deformations, are neglected.

15

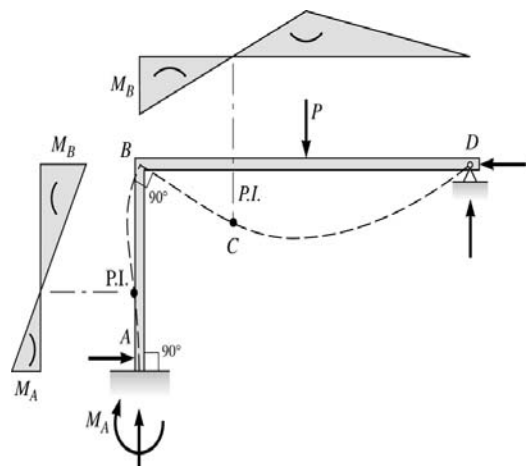

P.I. \equiv Point of Inflection

= zero moment location
for mechanically loaded
structures

16

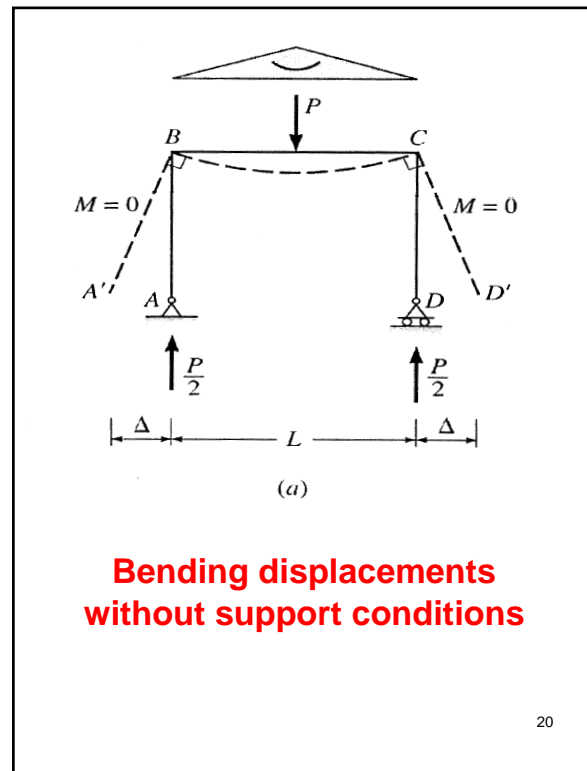
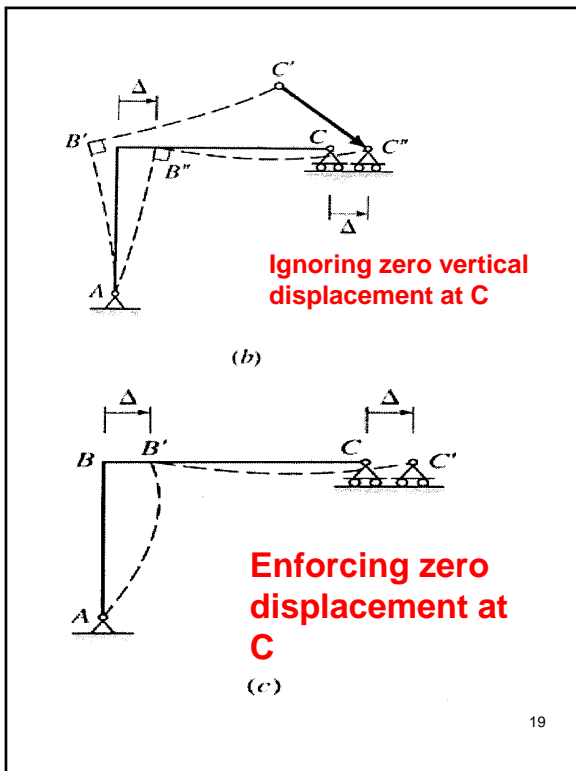
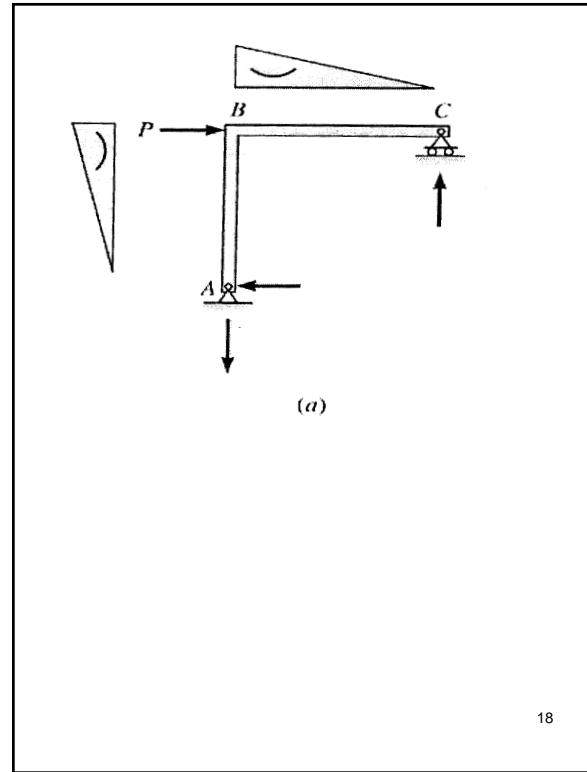
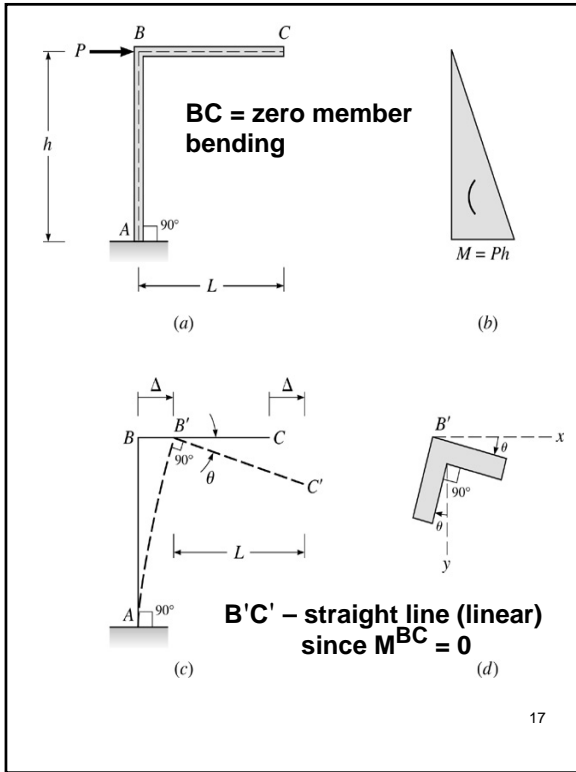

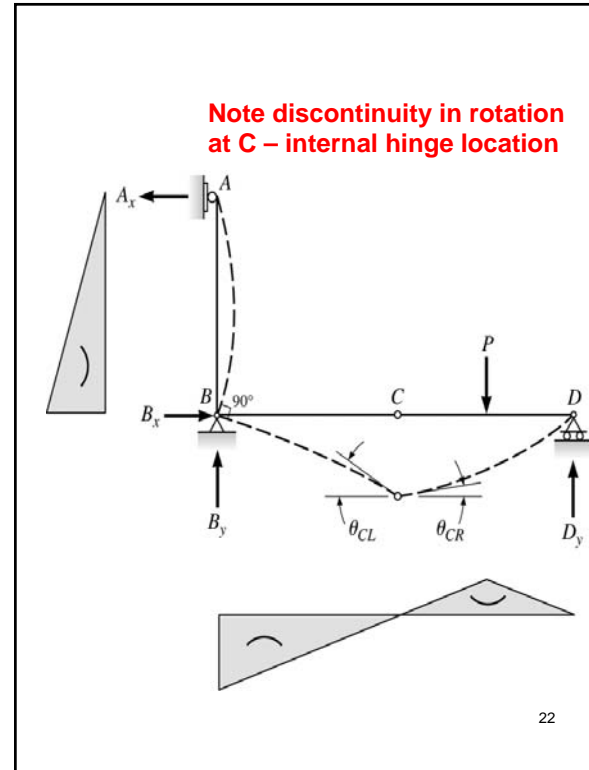
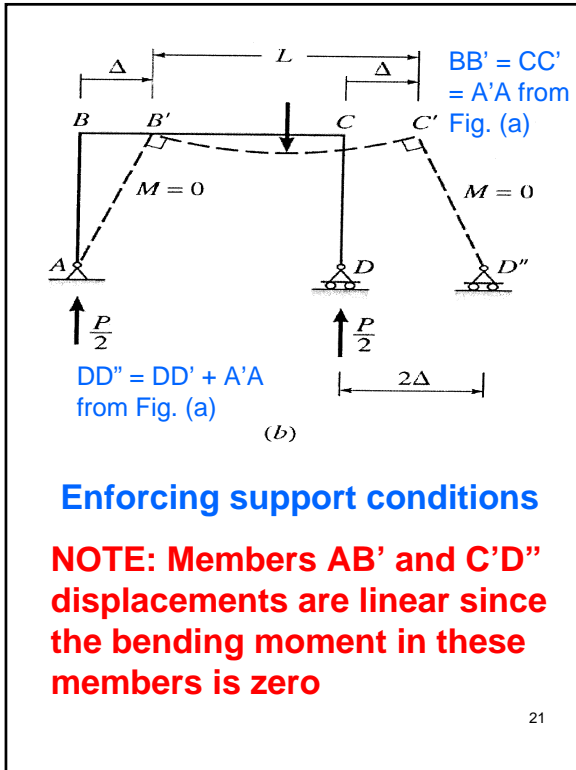

Axial Force, Shear Force and Bending Moment Diagrams for Plane Frames

Previous definitions developed for shear forces and bending moments are valid for both beam and frame structures. However, application of these definitions, developed for a horizontal beam, to a frame structure will require some adjustments.

Consider the portal frame shown on the next two slides.

23

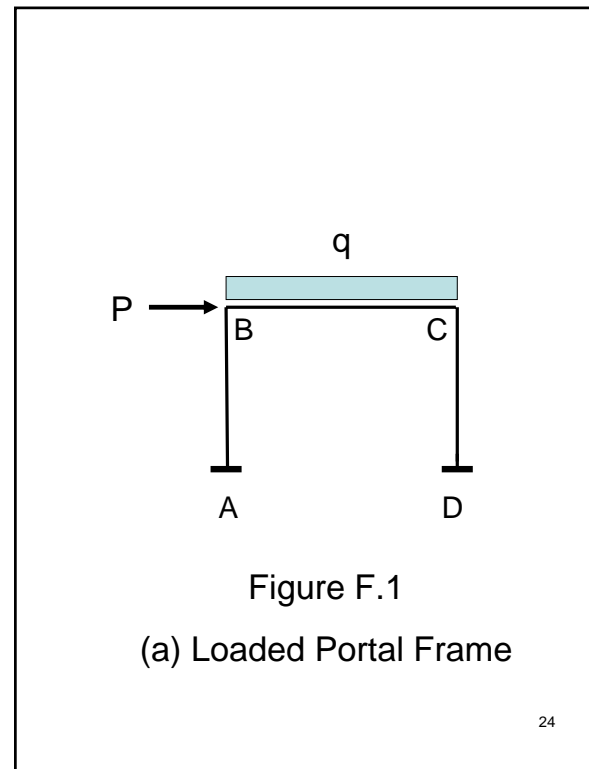

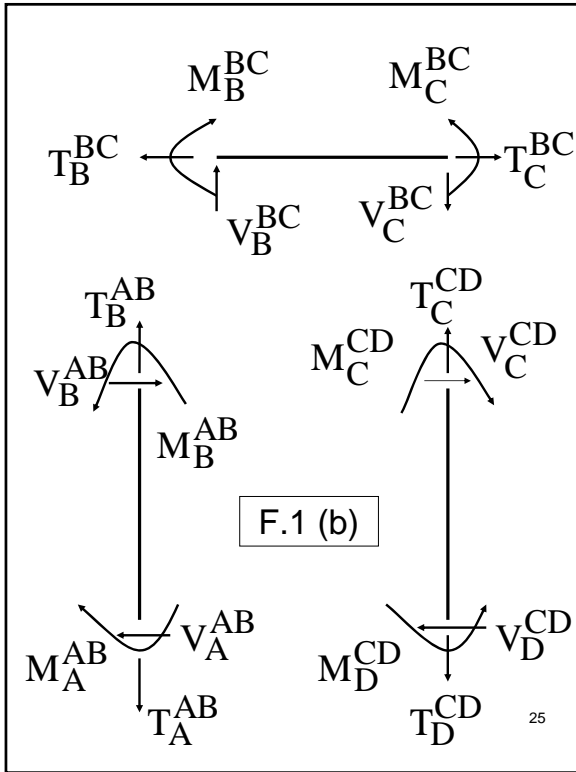

The positive sign convention consistent with beam theory is shown in F.1(b). As seen from F.1 (b), the **positive sign convention** is (a) tension axial force, (b) shear forces that produce clockwise moments and (c) bending moments that result in tension stresses in the interior frame fibers.

The sign convention of F.1(b) can be seen to be equivalent to the beam sign convention rotating columns AB and CD to line up with beam BC.

25

26

NOTE: For **multi-bay frames**, the usual practice is to define tension axial forces and shears that produce clockwise moments as positive for each member. However, the inside fiber for bending is not easily defined. Consequently, engineers choose to draw the bending moments on either the tension (common amongst structural engineers) or compression side of the members. They are not labeled as either positive or negative. Alternatively, a vector sign convention can be used – **usual for computer codes**.

27

Example Frame Problem 1

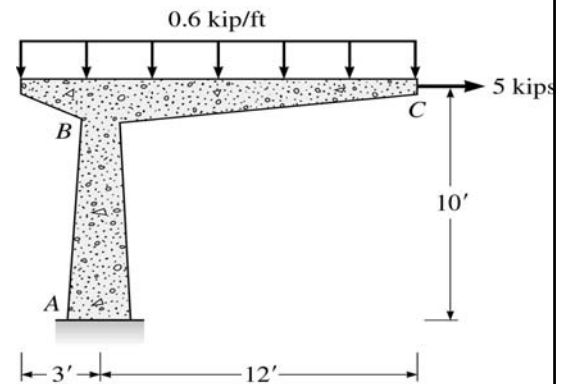

Calculate and draw the axial force, shear force and bending moment equations for the given frame structure.

28

Example Frame Problem 2

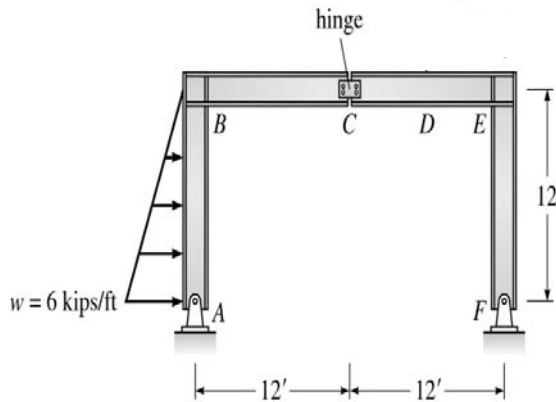

Calculate and draw the axial force, shear force and bending moment equations for the given frame structure.

29

Two-Dimensional Force Transformations

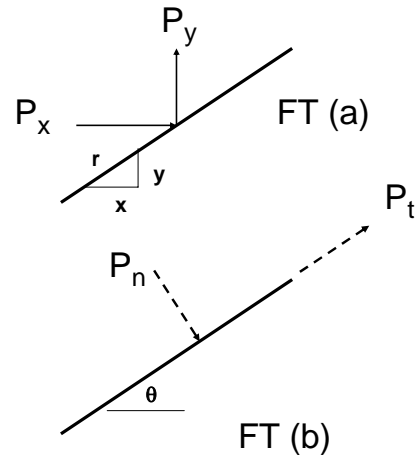

FT = Force Transformation 30

Suppose you are given the forces in FT (a) and you wish to transform these forces into P_n (normal) and P_t (tangential) as shown in FT (b). This **force transformation may be necessary so that you can calculate the member axial and shear forces.**

These force transformations are summarized on the next slide.

31

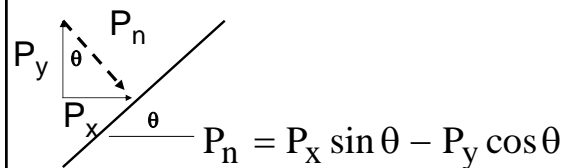

$$P_t = P_x \cos \theta + P_y \sin \theta$$

$$\cos \theta = \frac{x}{r}; \quad \sin \theta = \frac{y}{r};$$

$$\tan \theta = \frac{y}{x}$$

32

Example Frame with Inclined Member

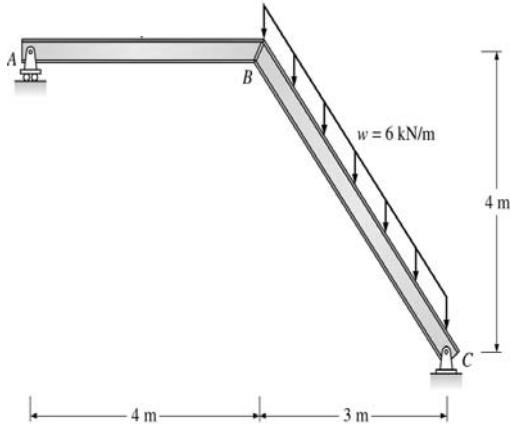

Calculate and draw the axial force, shear force and bending moment equations.

33

Degree of Frame Indeterminacy

Rigid Frame \equiv composed of straight members connected either by rigid (moment resisting) connections or by hinged connections to form stable configurations.

Rigid Joint \equiv prevents relative translations and rotations between connected members.

34

Statically Determinate \equiv the bending moments, shears, and axial forces in all its members, as well as the external reactions, can be determined by using the equations of equilibrium and condition, otherwise the frame is either unstable or statically indeterminate.

35

Summary

$3m + R < 3j + C$
 \Rightarrow statically unstable frame

$3m + R = 3j + C$
 \Rightarrow statically determinate frame, if stable

$3m + R > 3j + C$
 \Rightarrow statically indeterminate frame, if stable

$$I = (3m + R) - (3j + C)$$

$=$ **degree of static indeterminacy**

Redundants \equiv excess members and reactions

36

Alternative Approach

An alternative approach for determining the degree of static indeterminacy of a frame is to cut enough members of the frame by passing imaginary sections and/or to remove enough supports to render the structure statically determinate. The total number of internal and external restraints thus removed equals the degree of static indeterminacy.

37

This alternative approach provides the most convenient means for determining the degree of static indeterminacy of multistory building frames:

$$I = 3(N_g - N_f) - N_h - 2N_r - C$$

N_g ≡ Number of Girders in the structure

N_f ≡ Number of Free joints in the structure

N_h ≡ Number of Hinged supports

N_r ≡ Number of Roller supports

C ≡ Number of equations of Condition in the structure

38

Equations of Condition at a Joint
Detail w/ Three or More Members

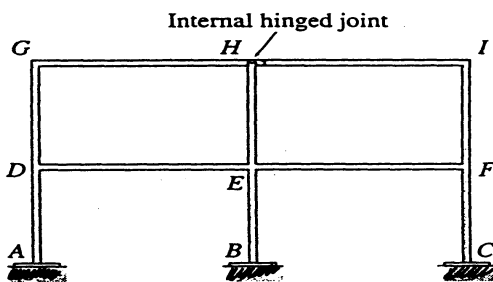

Any two of the following may be considered as equations of condition:

$$M_H^{EH} = 0, \quad M_H^{GH} = 0, \quad M_H^{HI} = 0$$

$$C_j = N_{bj} - 1$$

N_{bj} = Number of Beam (moment resisting) members at joint j

39

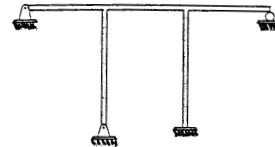

$$m = 5, R = 8$$

$$j = 6, C = 0$$

$$I = 5$$

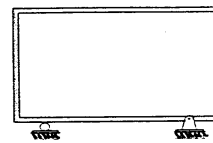

$$m = 4, R = 3$$

$$j = 4, C = 0$$

$$I = 3$$

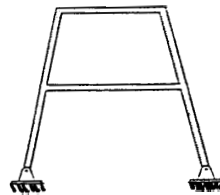

$$m = 6, R = 4$$

$$j = 6, C = 0$$

$$I = 4$$

$$I = (3m + R) - (3j + C)$$

40

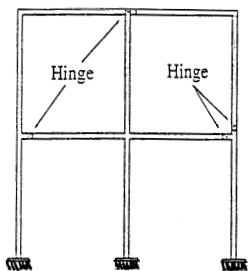

$$m = 10, R = 9$$

$$j = 9, C = 5$$

$$N_g = 4, N_f = 0$$

$$N_h = N_r = 0$$

$$I = 7$$

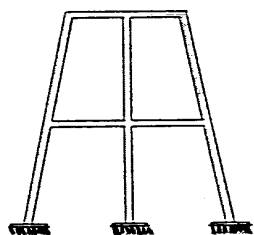

$$N_g = 4, N_f = 0$$

$$N_h = N_r = 0$$

$$C = 0$$

$$I = 12$$

$$I = 3(N_g - N_f) - N_h - 2N_r - C$$

41

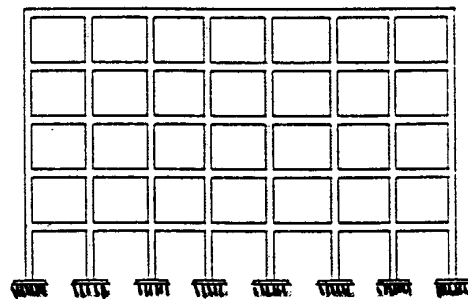

$$N_g = 35, N_f = 0$$

$$N_h = N_r = 0$$

$$C = 0$$

$$I = 105$$

42