

Plastic Analysis of Continuous Beams¹

Increasing the applied load until yielding occurs at some locations will result in elastic-plastic deformations that will eventually reach a *fully plastic* condition.

Fully plastic condition is defined as one at which a sufficient number of plastic hinges are formed to transform the structure into a mechanism, i.e., the structure is geometrically unstable.

1

¹See pages 142 – 152 in your class notes.

Additional loading applied to the fully plastic structure would lead to collapse.

Design of structures based on the plastic or limit state approach is increasingly used and accepted by various codes of practice, particularly for steel construction. Figure 1 shows a typical stress-strain curve for mild steel and the idealized stress-strain response for performing plastic analysis.

2

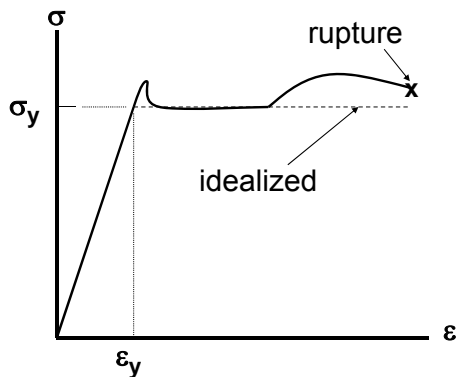

Figure 1. Mild Steel Stress-Strain Curve

σ_y = yield stress

ϵ_y = yield strain

3

ULTIMATE MOMENT

Consider the beam shown in Fig. 2. Increasing the bending moment results in going from elastic cross section behavior (Fig. 2(a)) to yield of the outermost fibers (Figs. 2(c) and (d)) and finally the two yield zones meet (Fig. 2(e)); **the cross section in this state is defined to be fully plastic.**

4

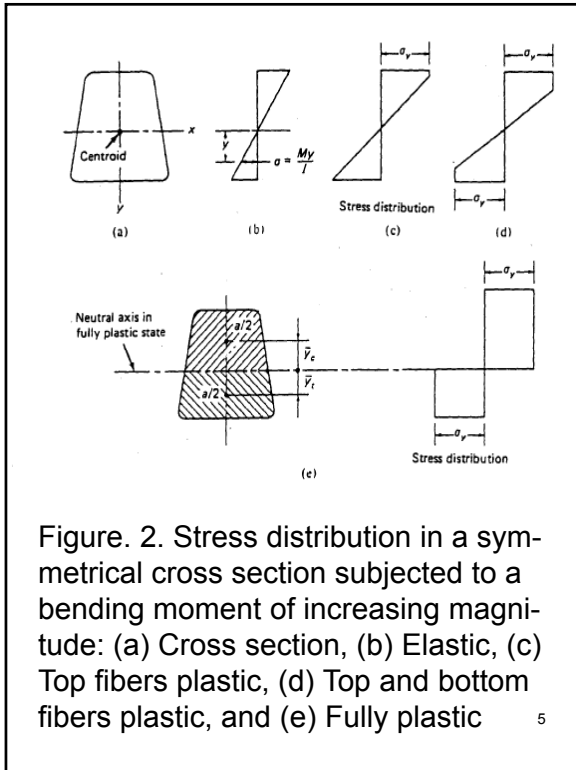

The ultimate moment is determined in terms of the yield stress σ_y .

Since the axial force is zero in this beam case, **the neutral axis in the fully plastic condition divides the section into two equal areas**, and the resultant tension and compression are each equal to $\sigma_y A/2$, forming a couple equal to the **ultimate plastic moment M_p**

$$M_p = \frac{1}{2} \sigma_y A (\bar{y}_c + \bar{y}_t) \quad (1)$$

6

The maximum moment which a section can resist without exceeding the yield stress (**defined as the yield moment M_y**) is the smaller of

$$M_y = \sigma_y S_t \quad (2a)$$

$$M_y = \sigma_y S_c \quad (2b)$$

S_t = tension section modulus
($\equiv I/c_t$)

S_c = compression section modulus
($\equiv I/c_c$)

7

c_t = distance from neutral axis to the extreme tension fiber

c_c = distance from neutral axis to the extreme compression fiber

I = moment of inertia

$\alpha = M_p/M_y > 1$ = **shape factor**

= **1.5 for a rectangular section**

= **1.7 for a solid circular section**

= **1.15 – 1.17 for I- or C-section**

8

PLASTIC BEHAVIOR OF A SIMPLE BEAM

If a load P at the mid-span of a simple beam (Fig. 3) is increased until the maximum mid-span moment reaches the fully plastic moment M_p , a plastic hinge is formed at this section and collapse will occur under any further load increase. Since this structure is statically determinate, the **collapse load P_C** can easily be calculated to give

$$P_C = 4M_p/L \quad (3)$$

9

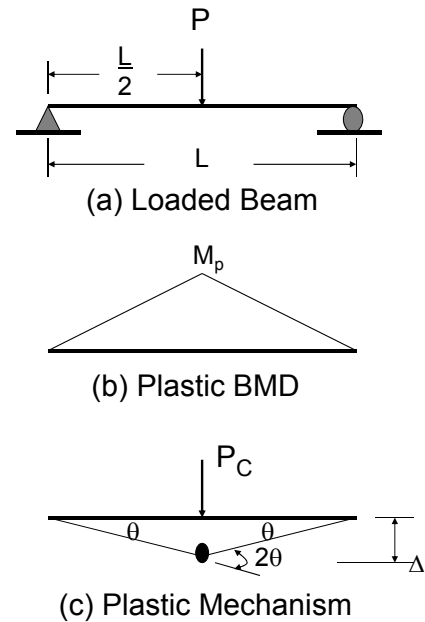
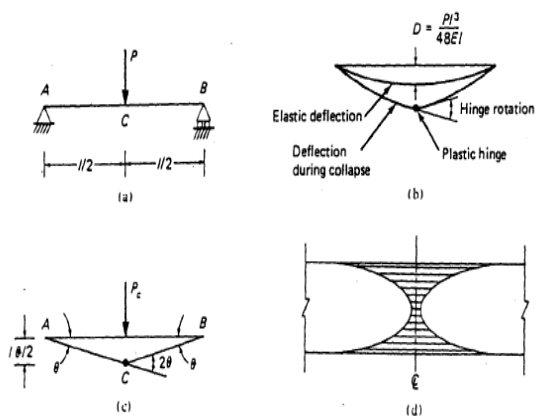

Figure 3. Simple Beam

10



Plastic Hinge Along the Length of the Simple Beam

11

The **collapse load of the beam can be calculated by equating the external and internal work during a virtual movement of the collapse mechanism (this approach is equally applicable to the collapse analysis of statically indeterminate beams)**. Equating the **external virtual work W_e** done by the force P_C to the **internal virtual work W_i** done by the moment M_p at the plastic hinge:

12

$$W_e = W_i \Rightarrow P_C \frac{L\theta}{2} = M_p(2\theta)$$

$$\Rightarrow P_C = 4M_p/L$$

which is identical to the result given in (3).

13

ULTIMATE STRENGTH OF FIXED-ENDED BEAM

Consider a prismatic fixed-ended beam subjected to a uniform load of intensity q (Fig. 4(a)).

Figure 4(b) shows the moment diagram sequence from the yield moment M_y

$$M_y = \sigma_y S (\equiv \frac{I}{c}) = \frac{q_y L^2}{12}$$

$$\Rightarrow q_y = \frac{12M_y}{L^2}$$

through the fully plastic condition in the beam.

14

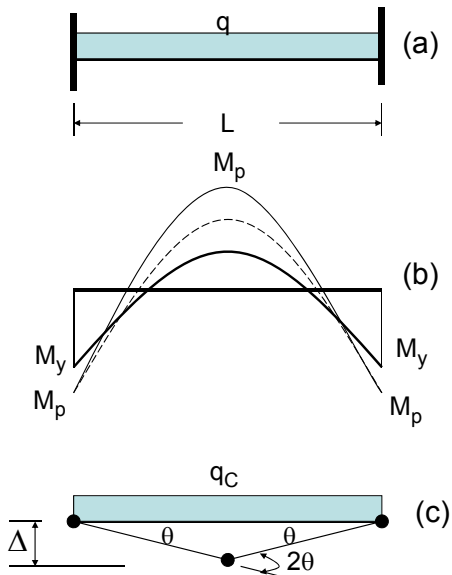

Figure 4. Fixed-Fixed Beam

15

The collapse mechanism is shown in Fig. 4(c) and the collapse load is calculated by equating the external and internal virtual works, i.e.

$$2 \left(\frac{q_C L}{2} \right) \frac{L\theta}{4} = M_p(\theta + 2\theta + \theta)$$

$$\Rightarrow q_C = \frac{16M_p}{L^2}$$

Sequence of Plastic Hinge Formation:

- (1) Fixed-end supports – maximum moment (negative)
- (2) Mid-span – maximum positive moment

16

ULTIMATE STRENGTH OF CONTINUOUS BEAMS

Next consider the three span continuous beam shown in Fig. 5 with each span having a plastic moment capacity of M_p . Values of the collapse load corresponding to all possible mechanisms are determined; **the actual collapse load is the smallest of the possible mechanism collapse loads.**

17

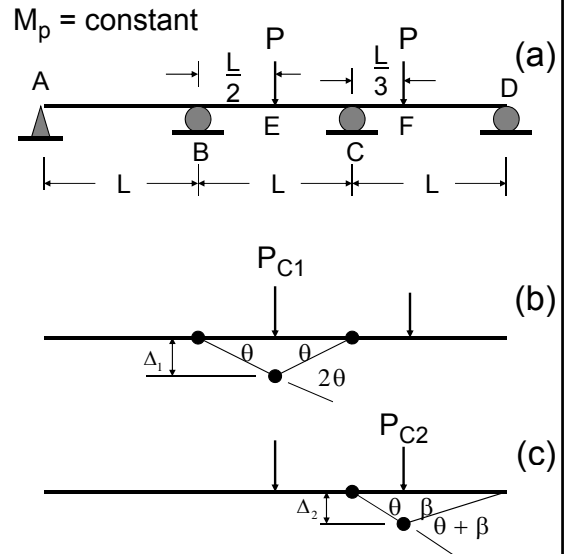

Figure 5. (a) Continuous Beam
(b) Mechanism 1
(c) Mechanism 2

18

For this structure, there are two possible collapse mechanisms are shown in Figs. 5(b) and (c). Using the principle of virtual work ($W_e = W_i$) for each mechanism leads to

Figure 5(b) ($\Delta_1 = L\theta/2$):

$$P_{C1} \left(\frac{L\theta}{2} \right) = M_p(\theta + 2\theta + \theta)$$

$$\Rightarrow P_{C1} = 8M_p/L$$

19

Figure 5(c) ($\Delta_2 = L\theta/3$):

$$P_{C2} \left(\frac{L\theta}{3} \right) = M_p(\theta + \theta + \beta)$$

$$\frac{2L\beta}{3} = \Delta_2 = \frac{L\theta}{3}$$

$$\Rightarrow \beta = \frac{\theta}{2}$$

$$\therefore P_{C2} \left(\frac{L\theta}{3} \right) = \frac{5M_p\theta}{2}$$

$$\Rightarrow P_{C2} = 15M_p/2L$$

20

The smaller of these two values is the true collapse load. Thus, $P_C = 7.5M_p/L$ and the corresponding bending moment diagram is shown below.

When collapse occurs, the part of the beam between A and C is still in the elastic range.

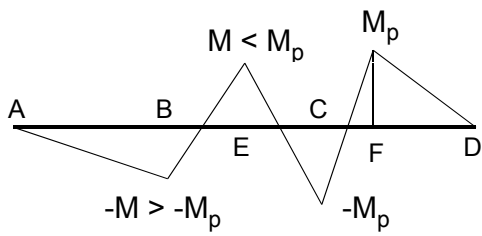

Collapse BMD

21

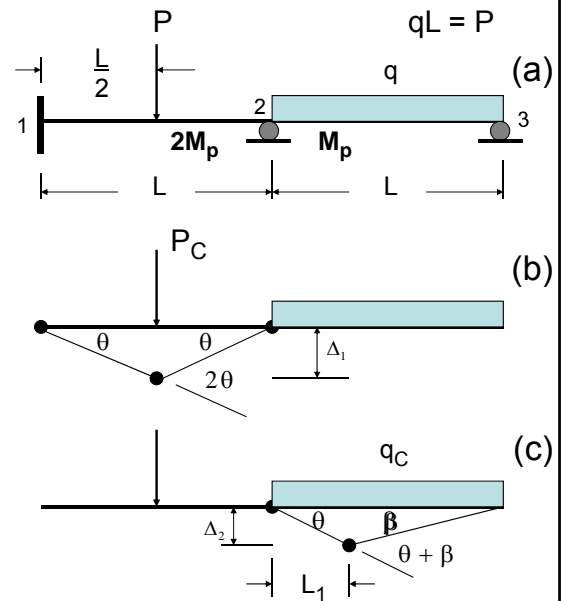

Figure 6. (a) Continuous Beam
(b) Mechanism 1
(c) Mechanism 2

22

The two span continuous beam shown in Fig. 6 exhibits some unique considerations:

1. the plastic moment capacity of span 1-2 is different than the plastic moment capacity of span 2-3; and
2. the location of the positive moment plastic hinge in span 2-3 is unknown.

23

Mechanism 1:

$$W_e = P_C \Delta_1 = \frac{P_C L \theta}{2}$$

$$W_i = 2M_p \theta + 2M_p (2\theta) + M_p \theta = 7M_p \theta$$

$$W_e = W_i \Rightarrow P_C = \frac{14M_p}{L} \quad (A)$$

Mechanism 2:

$$W_e = q_C L_1 \frac{\Delta_2}{2} + q_C (L - L_1) \frac{\Delta_2}{2} = q_C L \frac{\Delta_2}{2}$$

24

$$W_i = M_p\theta + M_p(\theta + \beta)$$

$$L_1\theta = \Delta_2 = (L - L_1)\beta$$

$$\Rightarrow \beta = \frac{L_1}{L - L_1}\theta$$

$$\therefore W_i = \left(\frac{2L - L_1}{L - L_1}\right)M_p\theta$$

$$\therefore W_e = \frac{1}{2}q_C L L_1\theta$$

$$W_e = W_i$$

$$\Rightarrow q_C L = \frac{2}{L_1} \left(\frac{2L - L_1}{L - L_1}\right) M_p \quad (B)$$

25

The problem with this solution for $q_C L$ is that the length L_1 is unknown.

L_1 can be obtained by differentiating both sides of $q_C L$ with respect to L_1 and set the result to zero, i.e.

$$\begin{aligned} \frac{d(q_C L)}{dL_1} &= \frac{-2L_1(L - L_1)}{(L_1)^2(L - L_1)^2} M_p \\ &\quad - \frac{2(2L - L_1)(L - 2L_1)}{(L_1)^2(L - L_1)^2} M_p \\ &= 0 \end{aligned} \quad (C)$$

26

Solving (C) for L_1 :

$$2L_1^2 - 8LL_1 + 4L^2 = 0$$

$$\Rightarrow L_1 = \frac{8L \pm \sqrt{(8L)^2 - 4(8L^2)}}{4}$$

$$= 2L - \sqrt{2}L$$

$$= 0.5858L$$

(D)

Substituting (D) into (B):

$$q_C L = \frac{11.66 M_p}{L}$$

(E)

27

Comparing the result in (A) with (E) and for $qL = P$ shows that the **failure mechanism for this beam structure is in span 2-3.**

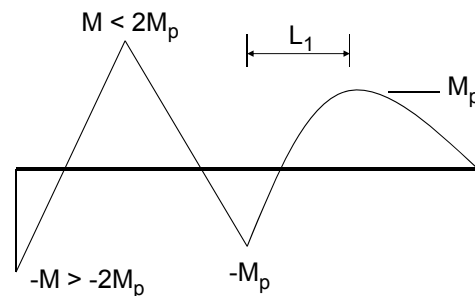

BMD for Collapse Load q_C

28

Direct Procedure to Calculate Positive Moment Plastic Hinge Location for Unsymmetrical Plastic Moment Diagram

Consider any beam span that is loaded by a uniform load and the resulting plastic moment diagram is unsymmetric. Just as shown above the location of the maximum positive moment is unknown. For example, assume beam span B – C is subjected to a uniform load and the plastic moment capacity at end B is M_{p1} , the plastic moment capacity at end C is M_{p2} and the plastic moment capacity is M_{p3} .

capacity at end C is M_{p2} and the plastic positive moment capacity is M_{p3} .

$$M_{p1} \leq M_{p3}; \quad M_{p2} \leq M_{p3}$$

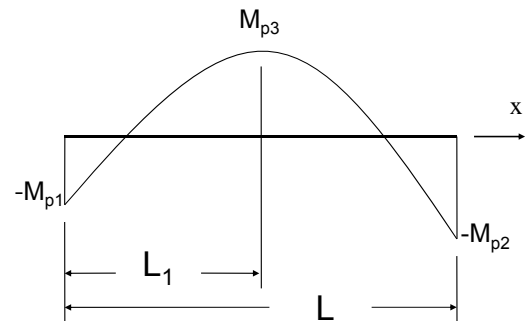

30

The location of the positive plastic moment can be determined using the bending moment equation

$$M(x) = ax^2 + bx + c$$

and appropriate boundary conditions.

(i) $x = 0: M = -M_{p1} = c$

(ii) $x = L_1: M = M_{p3} = aL_1^2 + bL_1 + c$

$$\Rightarrow aL_1^2 + bL_1 = M_{p3} + M_{p1}$$

(iii) $x = L_1: dM/dx = 0 = 2aL_1 + b$

Solving for a and b from (ii) and (iii):

$$a = \frac{-(M_{p1} + M_{p3})}{L_1^2}$$

$$b = \frac{2(M_{p1} + M_{p3})}{L_1}$$

32

(iv) $x = L$:

$$\begin{aligned} M &= -M_{p2} = aL^2 + bL + c \\ &= -(M_{p1} + M_{p3})(L/L_1)^2 \\ &\quad + 2(M_{p1} + M_{p3})(L/L_1) - M_{p1} \end{aligned}$$

$$\begin{aligned} 0 &= -(M_{p1} + M_{p3})(L/L_1)^2 \\ &\quad + 2(M_{p1} + M_{p3})(L/L_1) \\ &\quad - M_{p1} + M_{p2} \end{aligned}$$

Solving the quadratic equation:

33

$$\left(\frac{L}{L_1}\right) = 1$$

$$\pm \frac{\sqrt{4(M_{p1} + M_{p3})^2 - 4(M_{p1} - M_{p2})(M_{p1} + M_{p3})}}{2(M_{p1} + M_{p3})}$$

$$= 1 \pm \sqrt{1 - \left(\frac{M_{p1} - M_{p2}}{M_{p1} + M_{p3}}\right)}$$

$$\therefore L_1 = \frac{L}{1 + \sqrt{1 - \left(\frac{M_{p1} - M_{p2}}{M_{p1} + M_{p3}}\right)}}$$

34

EPILOGUE

The process described in these notes and in the example problems uses what is referred to as an **“upper bound” approach**; i.e., **any assumed mechanism can provide the basis for an analysis.**

The resulting **collapse load is an upper bound on the true collapse load.** For a number of trial mechanisms, the lowest computed load is the best upper bound. **A trial mechanism is the correct one if the corresponding moment diagram nowhere exceeds the plastic moment capacity.**

35