

## **AC 2007-80: TEACHING OPERABILITY IN UNDERGRADUATE CHEMICAL ENGINEERING DESIGN EDUCATION**

### **Thomas Marlin, McMaster University**

Department of Chemical Engineering McMaster University Hamilton, Ontario, Canada

Tom Marlin joined the Department of Chemical Engineering at McMaster University in Hamilton, Ontario, Canada, as NSERC Research Professor in Industrial Process Control in 1988. He received his Ph.D. from the University of Massachusetts in 1972; then, he practiced engineering for 15 years in the chemical and petroleum industries. In 1987, he served as the Visiting Fellow, for the Warren Centre Study located at the University of Sydney, Australia. During the one-year project, a team of over 40 academics and practitioners investigated methods for quantifying benefits from automation; the results of this project were published in a manuscript. Dr. Marlin is currently director of the McMaster Advanced Control Consortium (MACC), which develops relevant research through collaboration among university researchers and numerous companies. MACC consists of five professors, 17 industrial members and 25 university researchers, principally graduate students and post-doctoral fellows. He teaches university courses in process control, process analysis, problem solving, and optimization and has published a textbook in process control (Process Control, Designing Process and Control Systems for Dynamic Performance 2nd Ed., McGraw-Hill, 2000). In addition, he presents industrial short courses on process control, control benefits, and optimization. Dr. Marlin's research interests focus on improved dynamic performance of dynamic systems through real-time operations optimization and process control design.

Email: [marlint@mcmaster.ca](mailto:marlint@mcmaster.ca)

Personal WEB: <http://www.chemeng.mcmaster.ca/faculty/marlin/>

Consortium: <http://www.macc.mcmaster.ca/>

# Teaching "Operability" in Undergraduate Chemical Engineering Design Education

Thomas E. Marlin  
McMaster University

**Abstract:** This paper presents a proposal for increased emphasis on operability in the Chemical Engineering capstone design courses. Operability becomes a natural aspect of the process design course for a project that is properly defined with various scenarios and uncertainty. Key topics in operability are the operating window, flexibility, reliability, safety, efficiency, operation during transitions, dynamic performance, and monitoring and diagnosis. Each is discussed in the paper with process examples and its relationship to prior learning and process design decisions. The key barrier to improved teaching and learning of operability is identified as easily accessed and low cost educational materials, and a proposal is offered to establish a portal open to all educators.

## 1. Introduction

Engineering instructors and practitioners do not question the requirement for a design to be “operable”; however, without considerable discussion, no two engineers would agree on the meaning of operability or how to achieve it. Certainly, this is not a reasonable situation for the education of engineering students; therefore, a set of operability topics is proposed for undergraduate education.

For the purposes of this paper, operability will include the following eight topics.

1. **Operating window,**
2. **Flexibility** (and controllability),
3. **Reliability**
4. **Safety** (and equipment protection)
5. **Efficiency** (and profitability)
6. **Operation during transitions**
7. **Dynamic performance**
8. **Monitoring and diagnosis**

The topics have been selected to cover the most common issues in process plants and to reinforce prior learning, but they are not meant to be all-inclusive. Instructors can modify the topics to include their own insights or to emphasize unique aspects of a specific course and project.

These topics are not new and have been recognized as important. However, they are not addressed in standard engineering science courses (e.g., fluid mechanics or mass transfer) and are not typically addressed thoroughly in the design course. The contribution of this paper is in selecting the topics, demonstrating the principles for each topic, integrating the topics to show multiple effects for a design decision, and demonstrating their importance through numerous process examples. The intension of this paper is twofold; the first is to encourage greater coverage of operability topics, and second to begin collaboration among educators that will result in a consensus on the key operability topics and the development of essential resources to assist instructors in tailoring the topics to their courses.

This paper begins with learning goals and proceeds to design project definition that explicitly includes variation and directs attention from a design point to a design range. Then, the paper presents each of the operability topics briefly, giving examples of their impact on important design decisions. Cogent teaching examples are provided for each topic. The paper reports experiences from teaching operability and current barriers to including operability in design education. The paper concludes with a proposal to promote the development and sharing of educational materials to facilitate teaching process operability.

## 2. Learning Goals

A series of influential papers have proposed defining and communicating the learning objectives in three categories: attitudes, skills and knowledge<sup>1</sup>. Goals for the design course and the operability topics are discussed here with reference to these three categories.

### 2.1 Learning Goals for the Design Course

Design plays a central role in engineering education, giving a capstone experience to integrate and apply prior learning to a large-scale project. A typical process design course achieves a set of learning objectives, including the following components.

<u>Attitudes</u>	<u>Knowledge</u>	<u>Skills</u>
<ul style="list-style-type: none"><li>• Design is goal oriented, the result must satisfy a student-prepared specification</li><li>• Good design requires a mastery of chemical engineering sciences</li></ul>	<ul style="list-style-type: none"><li>• Process synthesis</li><li>• Flowsheeting</li><li>• Engineering economics</li><li>• Equipment sizing and cost estimating</li></ul>	<ul style="list-style-type: none"><li>• Defining and completing an open-ended project</li><li>• Report writing</li><li>• Oral presentation</li></ul>

The profession has nearly unanimous agreement that these learning goals are important and should be achieved by performing a project within the undergraduate chemical engineering curriculum. Examples of design projects are available in many textbooks and from CACHE<sup>2</sup>.

## 2.2 Learning Goals for Operability

This paper presents an argument for an enhancement in the curriculum by providing *additional* operability topics to achieve the following learning goals.

- | <u>Attitudes</u>  | <u>Knowledge</u>   | <u>Skills</u>  |
|---|--|--|
| <ul style="list-style-type: none"><li>• Process behavior never <i>exactly</i> matches theoretical predictions</li><li>• Operability cannot be an “add-on” after the equipment design has been completed</li></ul> | <ul style="list-style-type: none"><li>• Applying principles to the operation of processes</li><li>• Designing for a wide range of steady-state and dynamic operation</li></ul> | <ul style="list-style-type: none"><li>• Problem solving (diagnosing) process operations</li><li>• Achieving a good solution for a problem with multiple criteria</li></ul> |

An important advantage of the proposed approach involves the integration of topics that often appear as disparate “tricks” to students when presented without an integrating viewpoint. As a simple example, a by-pass around a heat exchanger can (1) increase the operating window, (2) improve reliability, (3) improve dynamic behavior, (4) affect process efficiency and (5) be a cause of potential process fault that is difficult to diagnose. Teaching operability techniques and showing students how common process structures and equipment affect operability enables the students to learn a structured approach for process operability analysis.

Presenting operability techniques for all industries is an impractical objective for the design course. However, the course can provide students with the generic concepts required to solve problems, such as

- (1) Learning the key topics in operability (asking the right questions),
- (2) Locating and using resources available to engineers when investigating operability (applying good problem solving and inquiry methods), and
- (3) Mastering selected design and control modifications available to enhance operability (knowing a suite of good solutions).

## 3. Operability in Design Education

While most engineering courses are focused on a specific technology, the design course consists of defining an acceptable outcome (product, production rate, etc.) and applying technical and professional skills in achieving the outcome. In this section, we discuss a few of the key aspects of the design definition that influence operability.

### 3.1 Designing for Realistic Scenarios

The traditional process design course is centered on a major project, in which students perform specific tasks, including (but not limited to) process synthesis, process flowsheeting, selection of materials of construction, rough equipment sizing, and cost estimation. Typically, the final report gives the process design for a *single operating point*.

It is the goal of designing for a *single operating point* that is being questioned here, since it is not adequate for engineering practice and limits the educational experience of the student.

The expansion of the design specification introduces many related topics, which will be combined under the term “operability” for the purposes of this paper.

The reason for considering a range of operations is often given as “uncertainty”; however, many factors are certain to occur, such as changes in feed properties, production rates, and product specification, as well as larger changes for startup and shutdown and removal of equipment for maintenance. These situations will *certainly* occur, and the process must function properly for all required operations anticipated in the specification. The equipment should be designed to operate as specified during these transitions, using the *known* variation in operating conditions and performance requirements.

### 3.2 Uncertainty

In spite of our best efforts, substantial uncertainty also exists in, for example, correlations for rate processes, physical properties, and efficiencies of equipment performance. Students should be encouraged to understand and quantify the likely range of uncertainty, which they can do by accessing the original references. They will appreciate the importance of uncertainty on their designs, and they should be required to report error bars and uncertainty estimates with their results, especially their economic analysis (an attitude that is missing from most current educational materials). Some typical sources of uncertainty are given in the following.

- Rates of chemical reactions, their yields, etc.
- Equipment performances (e.g., energy consumption for a specific separation)
- Rates of change of equipment performance (fouling, catalyst deactivation, etc.)
- Times for feed delivery and product shipment
- Times and durations of short-term equipment stoppage for repair

By raising the issue of uncertainty explicitly, students will be aware of the importance of knowing the basis for the models and data being used and for limiting designs to regions supported by the information.

### 3.3 Design specification

The proper design including operability topics will have little meaning for the single-point design. One solution would be to give the students a complete specification of the range of operations. A better approach is to give the students the design task of preparing the specification. For example, a design task could be to “design a waste water treating facility for a town of 50,000 people, which will grow in 10 years to 100,000 people, in western Ontario, Canada”. Before preparing a specification, the students would have to determine, for example, the amount of waste to be treated, the range of daily fluctuations, likely industrial spills, effluent water quality specifications, and likely variability of the conditions (rain storms, temperature, etc.). While performing this task, the students begin to recognize the fallacy of the “single-point design” approach and the importance of defining the range of conditions over which the process will operate.

The students should prepare a design specification based on a statement from the instructor and their further investigation that addresses the following issues.

#### **The nominal value and range (where applicable) should be given for each**

- Product specification (composition of a stream, function of a device, etc)
- Economics, project life, and any major changes during the life
- Production rate
- Geographical location, effluent and environmental limits
- Facilities available (shared within or outside the company)
- Feed composition
- Product qualities
- Process technology
- Equipment performance (catalyst deactivation, heat exchanger fouling)
- Feed delivery and product shipment which occur periodically
- Environmental changes (summer/winter cooling water and air temperatures)

Unfortunately, designing for a single point allows students to complete their capstone project with a design that could be unsafe, unreliable, uncontrollable, and inefficient, if it can be started up at all! In his book on engineering economics, Valle-Riestra (from Dow Chemical) stated that

“The principle sins of flowsheets used for economic evaluation are sins of omission ... frequently omitted items include storage tanks, surge tanks, duplicated equipment (for reliability), startup equipment, emergency safety equipment, ..”<sup>3</sup>.

When operability is ignored, even the basic economic evaluation can be in serious error!

## 4. The Eight Topics of Operability

The following topics were selected to concentrate on the most important issues and to provide the students with a structure or checklist of major categories. Naturally, additional topics can be included, and some issues can be located in more than one topic. Also, the topics can accommodate issues not covered in this review; for example, safety can include clean-in-place operations. However, the eight topics discussed in the following sub-sections provide a broad introduction to the analysis and design decisions involved in process operability.

### 4.1 The operating window

An important objective of process design is ensuring that the range of operating conditions defined in the specification can be achieved. To achieve the desired range, students will be required to select values for key decisions, such as process type (separation technology, reactor type, etc.), process structure (series, recycle, etc.), and equipment capacity (pump, reactor volumes, vessel diameters, etc). In addition, they determine the best values for key design variables that enable the plant to achieve the range required in the specification, for example, reactor temperatures and volumes, heat exchanger areas, materials of construction, and so forth.

The typical use of this analysis is to ensure that process equipment has a large enough capacity to achieve all expected operations. However, students must be aware that process equipment has minimum as well as maximum limits on its operating variables, for example, a minimum fuel rate to a boiler, a minimum reflux flow to a distillation tower, and a minimum flow to a fluidized bed. The results of this analysis must be a design that achieves the required operating window.

Students should see some operating windows presented graphically and be able to explain their shapes, which are usually not simple rectangles! For example, the operating window for a blending process is given in Figure 1. Naturally, the maximum production rate is attained at the maximum flow of both components. Therefore, the maximum product flow rate can be achieved at only one product composition.

Naturally, we must also consider key variabilities and uncertainties, which can only be defined when engineers have a comprehensive design specification and a thorough knowledge of the process models. Students should understand the accuracy of models for constitutive models, such as friction factors, heat transfer coefficients and equipment efficiencies. They must know the assumptions that limit the regions of application, for example, laminar or turbulent flow, horizontal or vertical tubes, etc. Also, they should acknowledge the uncertainty in the model structure and the danger in extrapolation beyond the data used in model building; a good example is reaction rate expressions, whose structure as well parameters are uncertain.

This author prefers to have the students use first principles to determine the limiting, or “worst case”, conditions of all uncertain (or variable) parameters. For example, the area required for the heat exchanger in Figure 2 can be determined for the base case data. However, we see that the cooling water temperature and the process flow rate vary over a range. In addition, the fouling factor and the film heat transfer coefficients have uncertainty associated with their

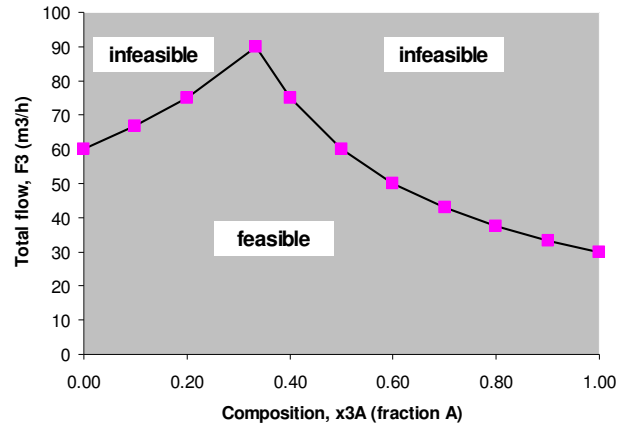
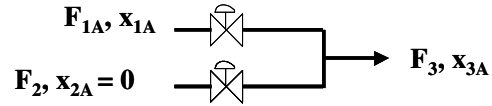

**Figure 1.** Operating window for a blending process with two components.

values. In many cases, the heat capacities of the fluids and the metal thermal conductivities are known with little error, considering the variability and uncertainty of other aspects of the design. Therefore, the design is based on the “worst case” values, i.e., the values that result in the largest area: these are the highest process inlet flow rate, highest cooling water temperature, highest fouling factor. To account for uncertainty in the film heat transfer coefficient, a small design margin might be allowed.

When specifying the range of parameters, engineers must use judgment and understand the impact of the values that they use. If very extreme values are used for every parameter and the simultaneous worst case for every variable is selected, it is possible to design the plant for a very unlikely scenario. In addition, any correlation in the variability should be noted. For example, if the highest production rate will when a specific extreme feed composition is not available, the scenario with both feed rate and composition extremes is very unlikely and must not be considered in the design. Also, the specification might not require full production rate of all products under some extreme conditions. A particularly difficult feed material might have a lower maximum production rate, or some products might not be manufactured when specific equipment is periodically unavailable due to maintenance.

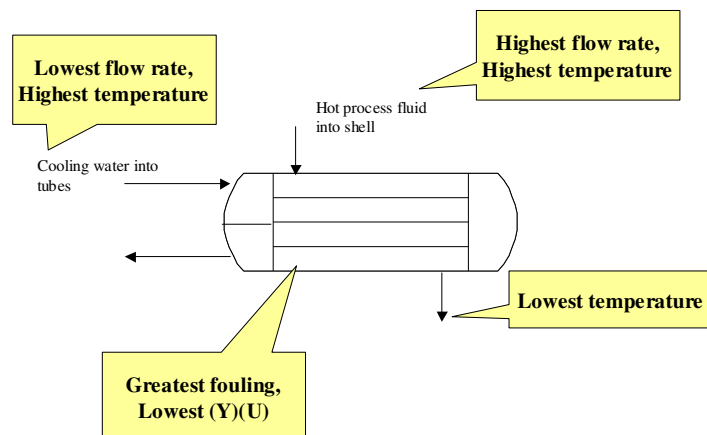

**Figure 2.** Take the worst-case conditions when determining the area for heat transfer. Use values that will occur when the plant should operate at full capacity.

**Figure 3.** Compressor with anti-surge recycle to enable operation when the feed flow is below the minimum required through the compressor.

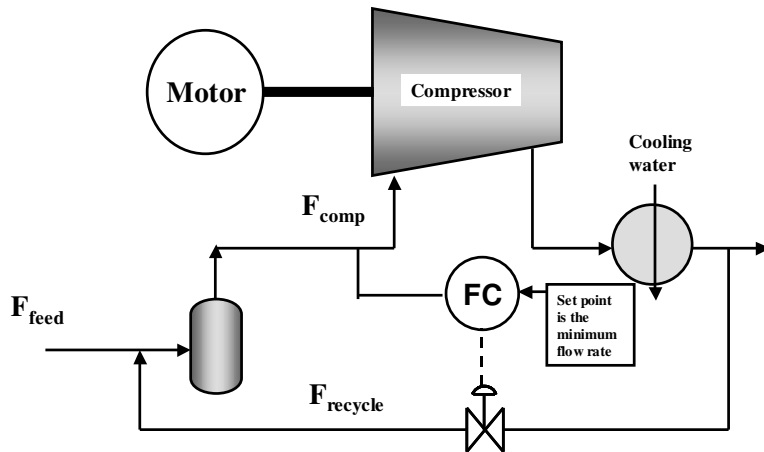

Ensuring that a design can achieve all points in a range, including lower flow rates for an uncertain plant is a challenging problem. It is important to note that design changes can have a large effect on the “size” of the operating window; some examples are given in the following.

- Recycle around a compressor to allow lower net flow rates (see Figure 3)
- Over-reflux a distillation tower to prevent violating tray hydraulic limitations at low feed flow rates
- Second pump to increase “capacity” when needed (series for higher pressure at the same flow, parallel for higher flow at the same exhaust pressure)

In addition to extreme operations defined by the external boundaries of the operating window, the student must consider the possibility of gaps or “holes” within the operating window, where a process becomes inoperable. Some examples of these gaps are pump cavitation in Figure 4 and flashing in an orifice sensor in Figure 5. An especially important consideration is the explosion region for concentrations, which certainly must be avoided.

The proposed approach requires students to use their process understanding and standard flowsheeting tools. The approach builds insight and is compatible with the students’ mathematical capabilities and today’s software tools.

However, it does not guarantee an optimal (or even feasible) design. More rigorous approaches are available that optimize the design of plants with uncertain parameters (disturbances and equipment performance) by selecting good values for design decision variables<sup>4</sup>. These approaches are very informative because they define the problem well. However, the solutions involve solving a multi-level optimization of an uncertain system that remains a challenging problem of research interest, and in the author’s view, they are not appropriate for an undergraduate design course.

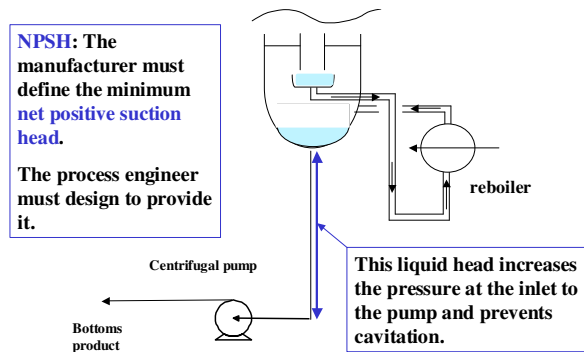

**Figure 4.** The need for a high enough pressure at the pump inlet to ensure that vaporization (and subsequent condensation) does not occur in a centrifugal pump.

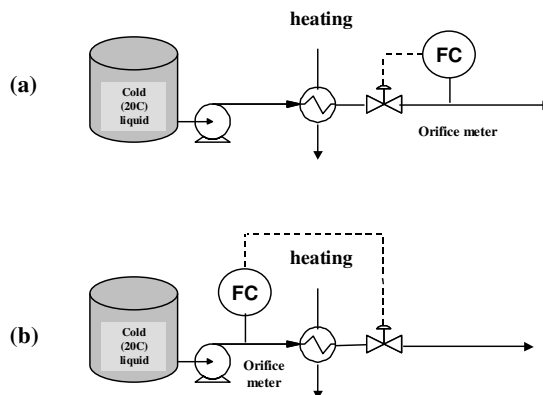

**Figure 5.** Orifice flow sensor.

- (a) A high temperature and low pressure could lead to flashing and poor accuracy.
- (b) A low temperature and high pressure should ensure the liquid does not flash.

The students will learn through experience in their projects that equipment capacities have a significant effect on capital and operating cost, and they will learn that unnecessary overcapacity can greatly reduce the profitability of a project.

In fact, the students should come away from a design course with disdain for gross overdesign of plants; for example, a 25 percent design factor can be excessive for some equipment, while being much too small for equipment experiencing large variation. Safety factors should be small and “for well tested processes, safety factors can approach zero percent”<sup>3</sup>.

We conclude by emphasizing that designing for a specified range of conditions is essential and that simply adding an arbitrary amount of excess capacity is not proper.

#### 4.2 Flexibility and Controllability

Once students recognize that the process will be required to achieve a range of operating conditions, they will accept the need to adjust selected (manipulated) variables to achieve key objectives such as safety, product quality, production rate and profit. Therefore, the process must have flexibility, i.e., it must have a sufficient number of manipulated variables that must be located so that the objectives can be achieved. The selection of the proper manipulated variables is not obvious, so that students should be taught to rely on fundamentals and innovation when providing flexibility. A nice example is adjusting the distillation condenser for control pressure. Flexibility analysis builds on the design equation,  $Q = U A (\Delta T)$ , which shows that flexibility is possible by adjusting (1) the heat exchanger area (A), (2) cooling temperature ( $\Delta T$ ), or (3) the coolant flow rate (U and  $\Delta T$ ). Each of these approaches is used in practice, with the proper choice depending on the cooling medium and desired speed of response. A few potential designs are given in Figure 6. It is interesting to note that the method shown in most textbooks

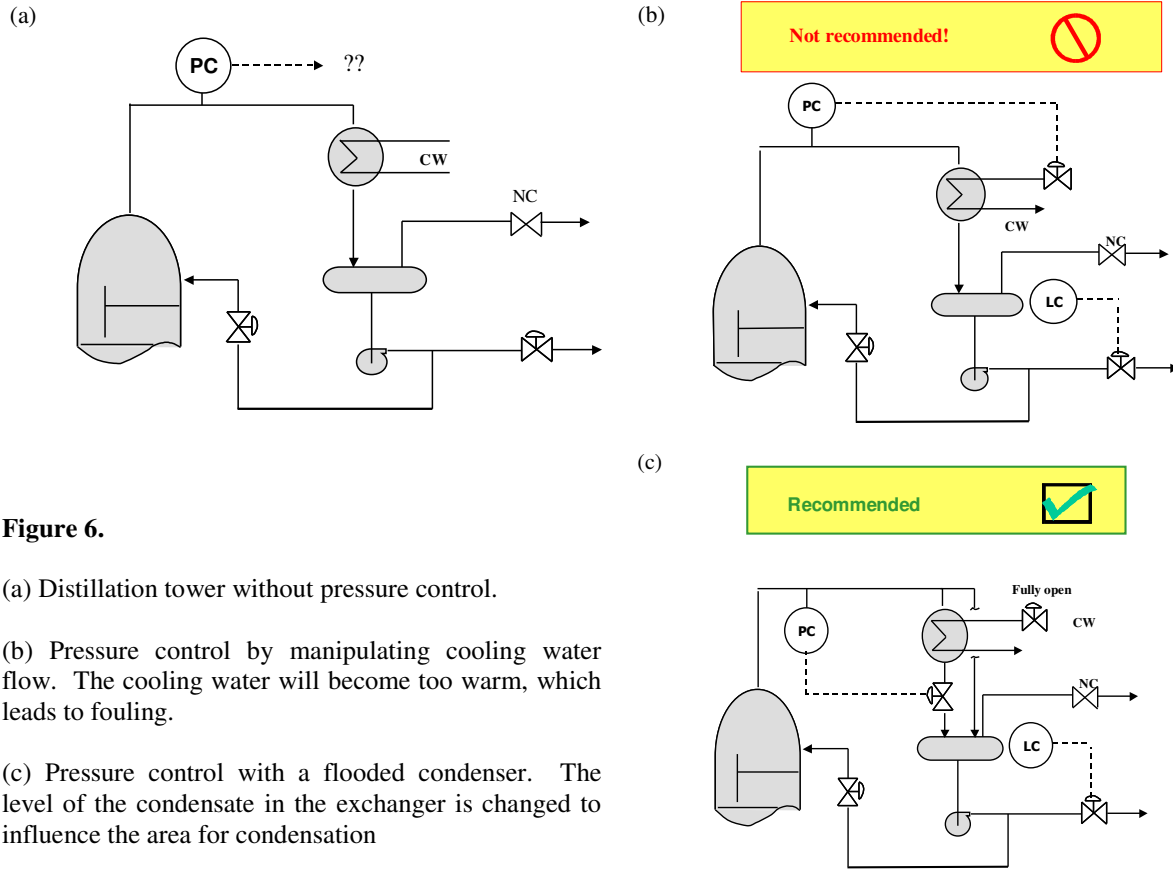

**Figure 6.**

(a) Distillation tower without pressure control.

(b) Pressure control by manipulating cooling water flow. The cooling water will become too warm, which leads to fouling.

(c) Pressure control with a flooded condenser. The level of the condensate in the exchanger is changed to influence the area for condensation

(adjusting cooling water flow rate to control pressure) is not recommended because of excessive fouling when the cooling water exit temperature is too high<sup>5,6</sup>.

Students also need to recognize that lots of process flexibility, i.e., many adjustable flows and power inputs, does not ensure that a specific set of variables can be influenced independently. We will term this controllability, which is generally defined as “the ability of a system to achieve a specified dynamic behavior for specified controlled variables by the adjustment of specified manipulated variables. Many definitions for controllability exist<sup>7</sup>, and we will restrict this discussion to a (very) limited definition that includes only steady-state behavior. A linear multiple input-output (MIMO) system is steady-state controllable if the rank of the gain matrix is equal to or greater than the output dimension. For teaching purposes, I generally simplify this to a square MIMO system and require that the gain matrix be invertible.

$$\begin{bmatrix} CV_1 \\ CV_2 \end{bmatrix} = \begin{bmatrix} 0 \\ 0 \end{bmatrix} = \begin{bmatrix} K_{11} & K_{12} \\ K_{21} & K_{22} \end{bmatrix} \begin{bmatrix} MV_1 \\ MV_2 \end{bmatrix} + \begin{bmatrix} K_{d1} \\ K_{d2} \end{bmatrix} D \quad (1)$$

The students should recognize

- When the loss of controllability is based on fundamentals (equilibrium, material balance, etc.) and cannot be affected by alternative choices of manipulated variables. An example

would be attempting to control the pressure and temperature of boiling water (saturated steam) to independent values.

- When the loss of controllability results from a limited process design and alternative designs and manipulated variables can lead to a controllable system. An example would be to control the temperature of superheated steam from a boiler, which can be achieved by adding a heat exchanger after steam leaves the vaporizer drum.

The best illustrative examples for teaching involve systems in which individual single-loop controllers could function properly, but all specified measured variables cannot be controlled by the specified manipulated variables. In Figure 7, the pressure and temperature in a boiler steam drum are specified for control by adjusting the two fuels. Either the pressure or temperature could be controlled, but both cannot be controlled simultaneously because the water is boiling. In Figure 8, two streams are mixed in a tank. Each stream has a different temperature and percentage of component A, and the composition and temperature of the tank effluent is to be controlled by adjusting the two inlet flow rates. (Note that the tank effluent exits by overflow; thus, the volume is constant.) Again, either individual effluent variable could be controlled, but both depend on the same ratio of inlet flow rates; therefore, the two effluent variables cannot be controlled simultaneously.

A typical controllability tests provide pointwise information and does not ensure the proper range or sensitivity. However, limitations in the range of compensation should be uncovered when evaluating the operating window. Limitations due to poor sensitivity (resolution) of the adjustment must also be investigated. If a large valve is needed for a large flow but if high resolution is required for small changes to the flow, a small valve can be placed in parallel and adjusted to regulate the flow.

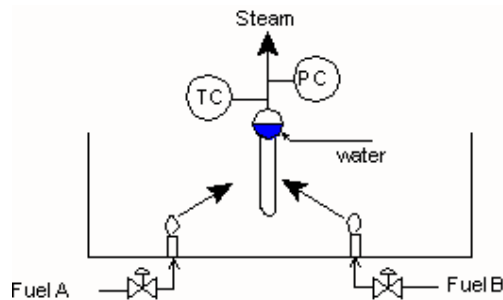

**Figure 7.** The pressure and temperature of saturated steam cannot be controlled by manipulating two fuels.

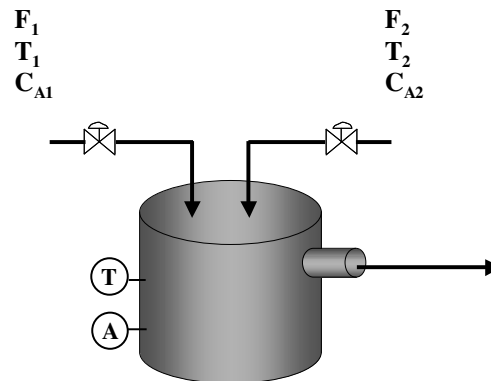

**Figure 8.** Overflow mixing tank in which the effluent composition and temperature cannot be controlled by manipulating the two inlet flow rates.

The issues raised here are general, while the analysis approaches are selected to be appropriate for undergraduate students. Considerable research continues in this topic. For example, the characterization of the flexibility of a process has been investigated by, among others, Swaney and Grossmann<sup>8</sup> and Rooney and Biegler<sup>9</sup>. Various definitions for controllability of a process are available<sup>7,10</sup>. A process could be controllable and yet require unreasonably small or large variations in the manipulated variable in response to a disturbance or set point change; a method for recognizing the “ill-conditioned” situation is given in McAvoy and Braatz<sup>11</sup>.

We see that the size of the operating window and the use of flexibility to achieve desired process conditions are complementary. The process equipment must have sufficient capacity to achieve all conditions in the desired operating window, and the process must be provided with sufficient “handles” (manipulated variables) to enable the plant personnel and control systems to achieve desired conditions. Both capacity and flexibility must be provided, which requires excellent process analysis and some experience, provided during the design course.

### 4.3 Process Reliability

Most processes operate 24/7, and designs must provide reliability to prevent even a short stoppage that requires a few hours to regain normal operation, because of potential high economic cost. Certainly, the selection of materials of construction that are suitable for process conditions (extremes in pressure, temperature, and compositions) is essential for highly reliable processes, and many resources are available for proper material selection<sup>12</sup>. Also, mechanical “ruggedness” is important; for example, a mixer and impeller should function for years without failure. The range of designs, along with guidelines for selection, is available from equipment suppliers. In addition, equipment should be used after an initial time for “break in” and be replaced before it wears out. Finally, performing periodic maintenance lengthens equipment life, and maintaining spares parts reduces the time to repair process equipment after a failure.

In addition, the structure of the design can have a strong impact on process reliability. A few typical process structures are given in Figure 9 that are guided by the principle that parallel structures typically have much higher reliability than series structures<sup>13</sup>. Reliability is defined in the following.

$$R(t) = 1 - \frac{n_{\text{failed}}(t)}{n} \quad \text{with} \quad \begin{array}{l} n = \text{the number of devices in operation} \\ n_{\text{failed}}(t) = \text{the number of devices failed by time } t \\ R(t) = \text{the reliability of the device} \end{array} \quad (2)$$

The reliability of series and parallel systems can be calculated using the equations in Figure 9, with the assumption that the failures are independent (no common-cause modes of failure) and the overall systems fails if (a) any one sub-system fails for the series system or (b) all parallel subsystems fail for a parallel system (or sub-system). We note that parallel equipment enables the process to continue in operation when one of the parallel components has failed for a short time.

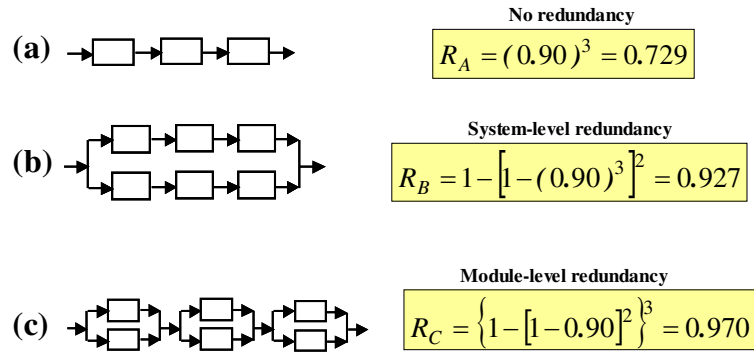
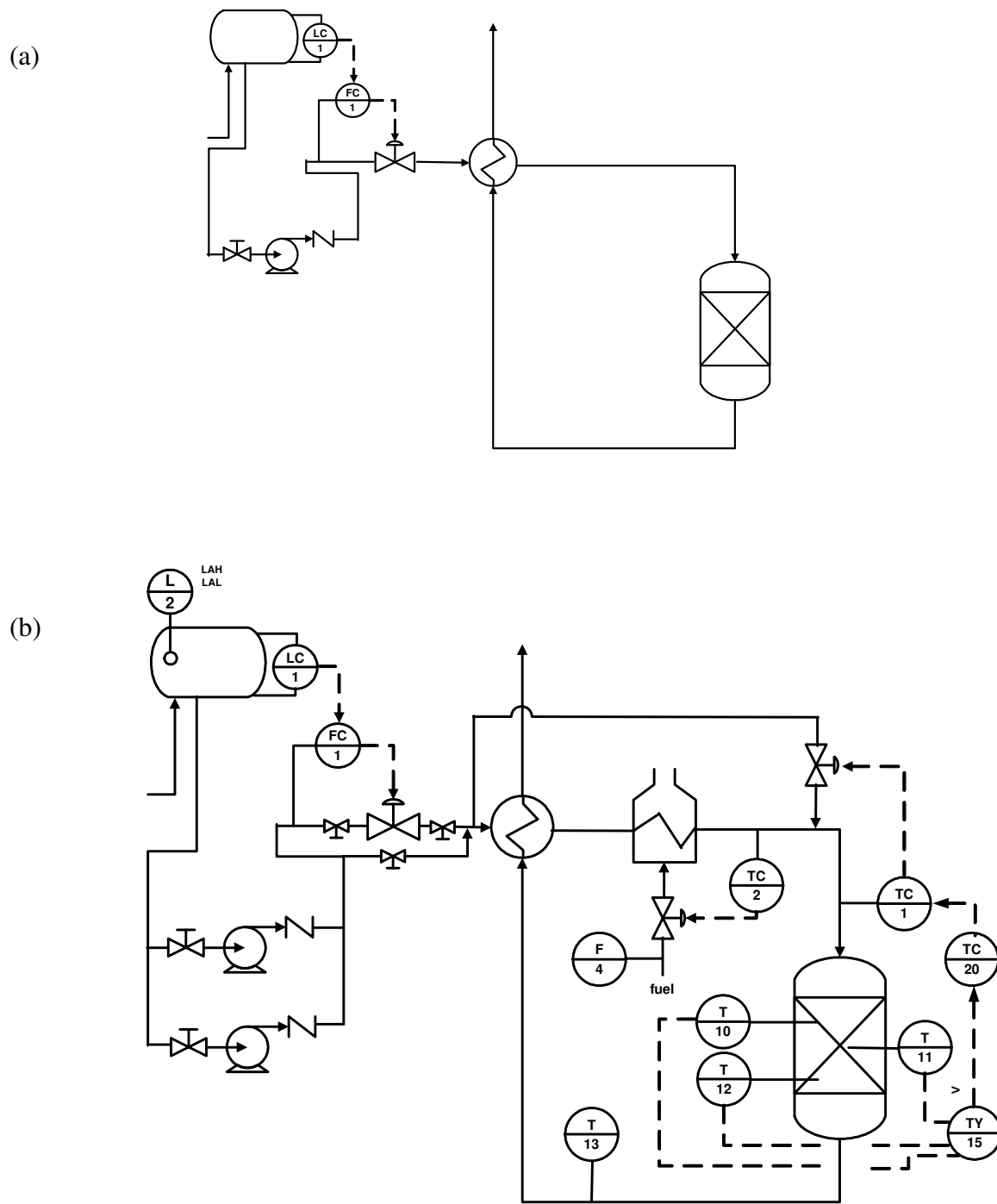

**Figure 9.** Reliability for several structures of elements. Each element has a reliability of 0.90 and all faults are independent.

Note that the “failure” of a component includes more than an unexpected fault that prevents proper operation; for example, required maintenance often requires that a piece of equipment be taken out of service periodically. Therefore, an added advantage of parallel systems is that they enable maintenance to be performed without interrupting production. An example is given in Figure 10b, which has two parallel pumps.

Another important design feature that increases reliability is the ability to by-pass equipment so that the process can continue with the equipment removed (at least for a short time at lower production rate or efficiency). To accommodate this situation, by-pass lines are provided for many pieces of process equipment, such as control valves (leaking), heat exchangers (fouling), and filters (cleaning). Each by-pass typically requires several manually operated block valves and additional piping, but without this investment, the process reliability would be unacceptably low. An example is given in Figure 10b for bypassing the control valve for flow controller FC-1. When the control valve is by-passed, a person can adjust the opening of the by-pass valve to approximately achieve the desired flow rate.

Some equipment is especially critical for plant operation because it affects the entire plant. For example, fuel, steam, compressed air and cooling water must be supplied reliably to the plant and if even one of these failed, a total plant shutdown would occur. Therefore, these utility streams are provided by "distribution systems" in which any one of multiple sources can supply any of multiple consumers. With a distribution system, the failure of one source usually does not affect the production in the plant, and failure of several sources simultaneously still provides enough material, e.g., steam, to the plant to operate critical equipment and prevent a total plant shutdown, which allows a faster and less costly recovery to normal operation. An example fuel gas distribution system is shown in Figure 11.



**Figure 10.** Packed bed chemical reactor with exothermic reaction and feed-effluent heat exchange.

(a) Basic process flow

(b) Piping and instrumentation drawing with selected operability features.

Finally, the stoppage of major equipment for repair or replacement is inevitable because duplicate equipment can be too costly. Acceptable plant reliability can be achieved by maintaining inventory before and after unit, so that both upstream and downstream units can continue operation. A design shown in Figure 12 reduces the effects of stoppages for critical equipment within the unit. However, increased inventory brings negative aspects, such as capital and operating costs, possible material degradation, and potential safety hazards. With increased emphasis on hazard reduction, design philosophies have been developed to “reduce, replace, and recycle” hazardous materials <sup>14</sup>, and many unfortunate examples of hazardous releases serve to motivate students to reduce inventories, e.g., the Bhopal incident <sup>15</sup>. Nevertheless, inventories are here to stay for many processes, and the negative aspects of inventory have to be balanced against the reliability improvement.

The engineer must decide the response time needed for each switch to backup equipment. The response can be made manually when time is not critical, or the response can be automated using process control when startup of redundant equipment must be immediate. Most plants have a great deal of by-pass equipment to provide continued operation when a component (valve, heat exchanger, etc.) is taken out of service and a number of parallel structures (pumps). The use of the by-pass or switch to back up usually requires personal intervention and often requires a person to go to the equipment location. However, the distribution systems of critical materials always provide automatic control to ensure an uninterrupted supply.

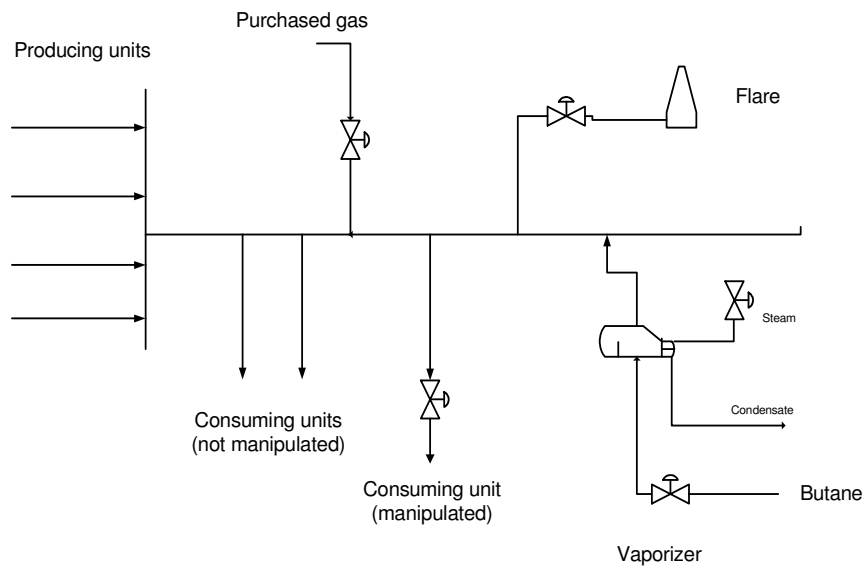

**Figure 11.** Typical fuel gas distribution system showing three sources of gas (producing units, purchased, and vaporized butane), consumers, and one large sink (flare).

**Figure 12.** Inventory between units can improve the reliability of the plant. A failure (or maintenance) in either unit does not require the other unit to be shutdown.

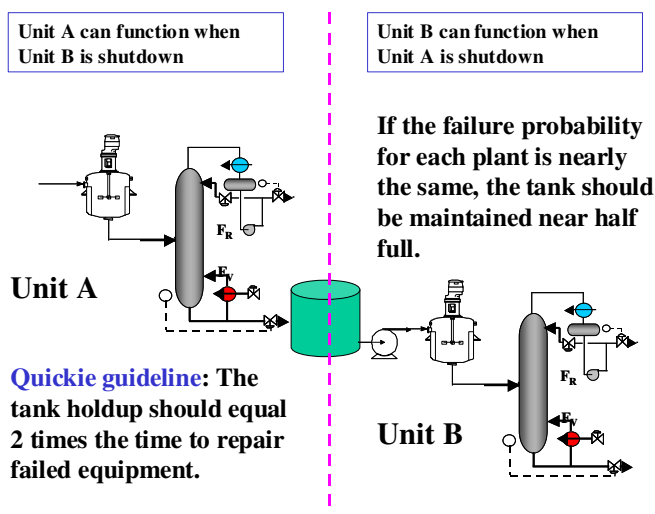

One component of the plant receives special attention to ensure very high reliability. It is the “brains” of the plant, i.e., the computation for the control system consisting of automatic controllers, visual displays, alarms, safety interlock systems (SIS), and associated electronics. The equipment is located in a blast resistant building that can be isolated to stop outside gases from entering the building. Power is backed up with batteries for uninterrupted supply and a generator for longer-term operation. In addition, a network of computers performs the computations, with automatic switching upon the failure of an individual processor. Additional features prevent a power spike from damaging the sensitive equipment, provide redundancy in power conversion, and shed lower priority power consumers to provide longer operation when normal power sources are lost. Naturally, this building and equipment is very expensive.

In all cases, increased reliability must be balanced against the cost of additional equipment. Designs without the conventional additions for reliability will have a very low capital cost but a very low operating profit, which will usually yield an unprofitable project. The typical process plant has redundancy where the consequence of a failure is high and the probability of a failure is unacceptable. For example, a spare pump requires the extra pump, all piping and valves, and control equipment to provide for immediate startup of the spare should the primary fail. Even this total cost of spare pumps is usually found to be a good investment, while the much higher capital cost of compressors prevents a spare being provided in most plants.

This coverage of reliability will likely be limited in a design course; however, it is essential to perform proper equipment design and cost estimation. Even a brief introduction will provide basic concepts used by students throughout their careers. Importantly, we hope that it will pique their interest and serve as a basis for later study during their professional careers.

## 4.4 Process Safety

Before beginning the study of the design approaches associated with safety, students need to understand the answer to a basic question, “How do processes become unsafe?” The students need to recognize that equipment can fail (including equipment provided to contribute to safety) and that people make mistakes. They would benefit from the review of at least one case study industrial accidents. Many informative case studies are available in books<sup>15,16</sup> and on the WWW<sup>17,18</sup>, and good case study documentation is available from the AIChE<sup>19</sup> for member universities and companies.

### 4.4.1 Layers of Safety Protection

Safety involves a vast range of topics, and the topic selection here is guided by the desire for general applicability. Safety is explained using the six layers proposed<sup>20</sup>.

1. Basic Process Control Technology (BPCT)
2. Alarms
3. Safety Interlock Systems (SIS)
4. Pressure Relief
5. Containment
6. Emergency Response (within the plant and neighboring community)

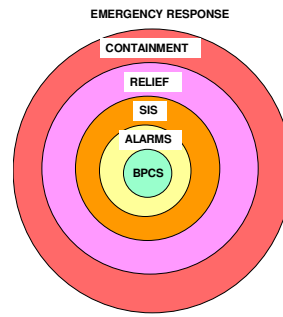

In the course described here, the first four layers are addressed in some detail, as shown in Figure 13. Since students have already completed a course in process control, the coverage of the lower levels of BPCT (alarms, valve failure positions, automatic control loops) can be covered quickly relying on exercises to refresh the students’ memories. Typically, the pressure relief and automated safety control levels are new to students, and in this author’s opinion, the

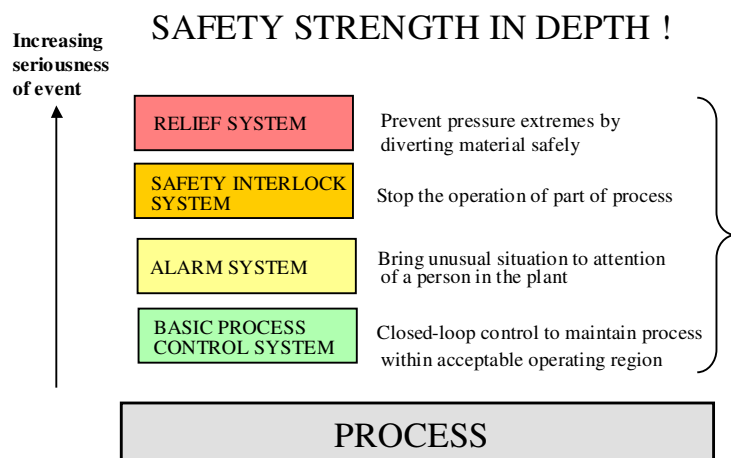

**Figure 13.** Schematic of the four layers of control for safety.

topics are essential for every practicing engineer. Pressure relief should introduce typical devices, guidelines for their selection, and most importantly, identify locations where the devices should be located <sup>21</sup>. Automated “Safety Interlock Systems” or “Safety Instrumented Systems” (SIS) perform extreme actions to prevent unsafe conditions from occurring <sup>20</sup>. Emphasis is placed on identifying scenarios requiring an SIS, selecting sensors, and placing final elements to implement the proper response; implementation via PLC’s and ladder logic are not covered. In addition, students must be introduced to special equipment required when the pressure relief or SIS diverts material from product facilities; typically, the equipment involves safe storage (tanks or ponds), neutralization, combustion (flare) or release to the environment for benign materials like steam.

The hierarchical layers enhance safety because subsequent layers will lessen the affects of an incident if previous layers fail to act or do not have sufficient capacity to completely compensate for the incident. This is strength in depth!

All of these safety levels are enhanced with techniques from reliability.

- **Redundancy** - For example, redundant sensors are used for critical control and SIS systems; an example is shown in Figure 10b, where several temperature sensors are used to identify the hottest temperature in a packed bed. The highest temperature from T10, T11, and T12 is selected by TY15, and the highest temperature is used as the control variable for the feedback controller TC20. The bed temperature controller TC20 resets the set point of the inlet bed temperature controller TC10 in a cascade structure.
- **Diversity** - Reliability is also enhanced by the principle of diversity, where a redundant sensor based on a different physical principle is used to greatly increase the reliability of the automated system. An example in Figure 10b shows a liquid level measured by two sensors, one for continuous control (e.g., hydrostatic head) and the second for an alarm (e.g., a float).

#### 4.4.2 HAZOP Study Method

All of the prior topics, especially flexibility, reliability and safety, are integrated through lessons and exercises using the hazards and operability “HAZOP” method <sup>22,23</sup>.

This method provides a structure for small teams of students to apply their knowledge and creativity to realistic process problems. The structure enables everyone in the group to concentrate on the same unit/node/parameter/guideword at the same time.

This focus enables everyone to benefit from the insights of their colleagues as they work in HAZOP groups.

In most cases, the HAZOP analysis is performed based on qualitative and semi-quantitative analysis. This type of qualitative analysis is used daily by engineering practitioners, so that the time and effort in the course is well justified. The students should be required to design specific solutions, with sketches on P&I drawings, not simply suggest “more flexibility”, “SIS” or “improved control”. However, the time-consuming documentation associated with an industrial HAZOP is not a productive use of limited time in a university course.

A sample HAZOP sheet for one case (parameter/guideword) is given in Table 1. The unit is a fired heater, and the node is the feed flow. A few sample entries are shown in the table, but additional entries are possible. Students would be expected to address at least four different parameter/guideword combinations during a 50-minute tutorial.

#### 4.4.3 Equipment Protection

The topic of equipment protection is integrated with safety because equipment failures usually lead to hazards and because the solutions require similar techniques (alarms, shutdowns, etc.). By this organization, hazards and equipment protection are introduced and addressed without duplication. For example, consider the process in Figure 14 with a positive displacement pump. The regulation of flow addresses flow rate control (BPCT by recycle manipulation) and overpressure protection (pressure relief) simultaneously. In addition, the use of SIS to protect equipment, even with extreme measures like equipment shutdown, complements safety.

#### 4.4.4 Safety via Chemistry and Process Structure

Finally, safety can be enhanced by fundamental modifications to the process chemistry or process structure. Methods have been described for reducing hazards by intensification, substitution, attenuation, limitation, and simplification<sup>14</sup>. In addition, special considerations for food and bio-chemical applications involve hygiene, toxicology, and clean-in-place. Different instructors will place different emphasis on choice of chemistry as a way to influence safety; the topic can be introduced as part of the course learning materials or within a specific project.

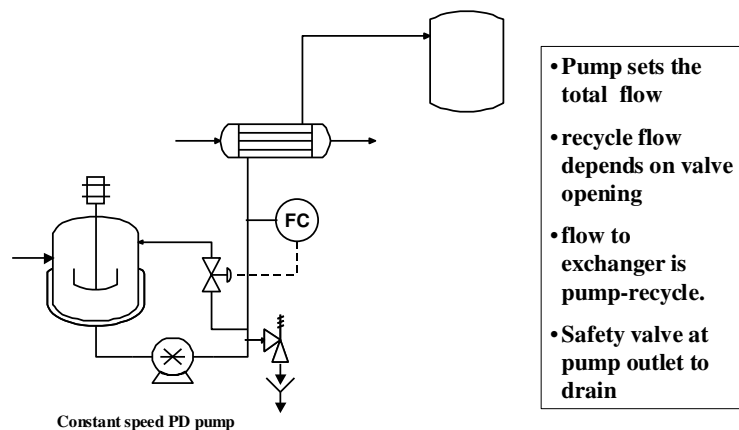

**Figure 14.** Operability for a constant-speed, positive displacement (PD) pump showing the combination of equipment protection and safety.

**Table 1. Sample HAZOP form with entries for a single parameter/node/guideword**

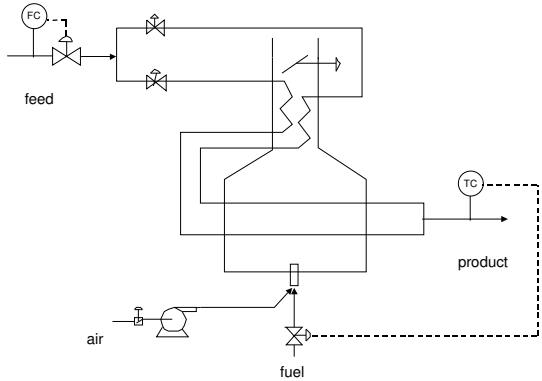

**HAZOP FORM**

Unit: Fired heater

**Note the specific location**

Node: air pipe after compressor and valve

Parameter: Pressure

Guide Word	Deviation	Cause	Consequence	Action
lower	Low pressure in the fuel pipe node	Stoppage of power to motor or turbine turning the compressor	Uncombusted fuel in the fire box – danger of explosion  Uncombusted fuel – wasted fuel	SIS based on the rotation of motor shaft *
		Break of coupling between motor and compressor	“	SIS based on rotation of compressor shaft*
		Failure of compressor, e.g., breakage of blades	(plus danger from flying metal)	“
		Closure of air valve due to failure	“	Fail open valve
		Any of the above	“	SIS that measures the flow of air after the pipe and activates the shutdown if the flow is too low
		Closure of air valve due to poor decision by operator	“	Air flow controller with ratio to fuel flow

**Notes:**

- The red actions are not recommended. They compensate for only a limited number of causes. The red actions have an asterisk (\*) if you are reading a b/w copy.
- The blue actions are recommended. They compensate or prevent important causes. The key point is that measuring the air flow identifies failures in the motor, compressor, valve, or pipe.

## 4.5 Operation During Transitions

Many processes are designed to operate at steady-state conditions during normal operation, but they must experience transitions during important situations, such as start-up, shutdown, and regeneration. Also, some processes are not designed for steady-state operation; batch processes are the most common examples. Therefore, process equipment and operating procedures are required to be suitable for operating during important transitions.

### 4.5.1 Transition Operation in Steady-State Plants

For the steady-state processes, equipment must be provided for transitions. Usually these processes are highly integrated, including sharing heat transfer and material flows among several units or plants. This integration increases efficiency and with proper control, can be operated without unfavorable effects on dynamic performance.

- **Startup and shutdown** - Integrated process designs face a conundrum, because many sources of material and heat transfer are only available when the process is in operation. Thus, how can the process be started-up? For heat transfer, this usually requires additional equipment. For example, the feed-effluent system in Figure 10b might operate without external heat, i.e., with the heater off, during continuous operation but cannot be started up without the additional heater.

For material integration, this situation usually requires storage of material; for example, a biological process requires “seed” microorganisms when starting up a reactor. Also, material produced during start-up might not be saleable; in such situations, equipment is needed to store the material for later recycle processing or alternative use, such as fuel.

During these transitions, the equipment can be operated with very different conditions. For example, a chemical reactor with a normal operating temperature of 830 °C will start at ambient and proceed slowly to its normal temperature. Usually, separate sensors with very large ranges are provided for the transition operation. In the same vein, flow rates can be quite different and additional valves can be required.

- **Regeneration** - Transitions for “regeneration” provide special challenges. Here, we use regeneration to denote a wide range of periodic process steps to return the equipment to “start-of-run” performance. It can involve regenerating a catalyst or an adsorbing/absorbing material, or it can involve cleaning equipment to maintain hygiene. Special piping is required to provide the transition materials and to collect the effluents. Also, since the regeneration materials can differ greatly from the typical process, more expensive equipment materials can be required, for example, stainless steel or glass lining for acid regeneration. For equipment sizing, the regeneration materials, inflows and effluents, must be handled at rates potentially very different from typical operation, which tends to be overlooked because of their infrequent use.

- **Short Steady-state Runs** – In some processes, many different products (levels of purity or material properties) are produced, and each product is produced for a relatively short time by operating the equipment at steady state. This frequent switching is required because of the need to supply the market for all products combined with limited product storage due to cost, safety and product quality requirements. Examples are lubricating oil production and the fluid-bed polyethylene reactor operation.

Equipment issues for frequent switching of operations are similar to those previously mentioned. Since these disruptions occur frequently, they produce considerable “mixed” product, which could lead to a significant economic loss. Therefore, carefully planned procedures and automatic control of each switch should be implemented to reduce the time required and the “off-specification” material produced.

- **Load Following** - Some units act as “utilities”, in that they must provide material when other units require it. Examples include steam boilers, fuel vaporizers and hot oil flow for heat exchange (hot oil belt). These units may have to respond quickly and without prior warning with large increases or decreases in their production. This often requires that large units (or many smaller units) remain in operation.

#### 4.5.2 Batch Processes

Batch processes are selected for lower production rates, but they can be very profitable. We have seen the importance of the design definition, which is more complex for batch systems than for steady-state systems. Only two key batch definition issues will be addressed here.

- First, since the operation is not at steady state, the design requires knowledge of the best values for key variables during the batch. Typically, flow rates, temperatures, and pressures are adjusted to follow a *desired trajectory or path* from the initial to final states of the batch. Generally, the best operation is determined by solving an optimization problem, and several nice examples are given in Seider et. al.<sup>24</sup>. The transient behavior of each unit during a batch is required to specify the equipment for the unit. For example, the average steam consumption over the batch is not used to size the steam piping and valves; the maximum steam flow rate is used.
- Second, the integrated operation of the entire plant is required. The integrated operation provides information of how long and when each equipment is utilized to produce the required product. The schedule for the plant can be improved by increasing the number of identical, parallel equipment and by adjusting the capacity of each. The schedule is required to determine the times for cleaning, the material inventories between equipment, and the flow rates between equipment.

Again, we see that the operation of the plant is affected strongly by the equipment available. The individual equipment trajectories and the plant production schedule used for design are only a proposal that will be modified frequently in response to disturbances (production rate, feed properties, etc.) and to uncertainty in the models used during design. Thus, process control should be used to achieve a flexible equipment trajectory and immediately

compensate for disturbances in, for example, heating temperature. Also, determining a plant production schedule is a challenging task and computer tools should be available to the plant personnel to respond to disturbances such as the ratio of products in a multiproduct plant.

Unlike steady-state flowsheeting, the simulation of a batch process to find a feasible and near-optimal schedule with equipment capacities remains a challenging task. Reklaitis<sup>25</sup> discusses many important issues and provides valuable references for further investigation into this topic.

#### 4.6 Dynamic behavior

Rapid responses to disturbances and to set point changes are required for critical process variables. This requirement can be achieved only if the process equipment and control system are capable of providing fast compensation. As is well recognized, no control algorithm can control a poorly designed plant (from the dynamic response perspective). As an example, a fired heater is often used to preheat the feed to a fixed bed chemical reactor. In typical designs, the reactor inlet temperature is controlled by adjusting the fuel to the fired heater. However, for very sensitive reactors, with highly exothermic reactions as in Figure 10b, a faster means of control is desired. Therefore, a by-pass stream is provided around the exchanger and heater to provide a fast mixing process for temperature control. The correct, but unconventional, process design with by-pass follows from the application of the simple principal that fast feedback dynamics are essential when tight control is absolutely required.

Naturally, dynamic behavior builds on the prior process control course. The operability topic provides more emphasis on two issues usually not given sufficient attention in the first course; multiloop control and the effects of process design on control. For example, Figure 15 presents some general guidelines on the effects of process behavior on the performance of a single-loop control loop. Also, Figure 16 shows how process modifications and applications of cascade and feedforward can improve the dynamic performance of a system.

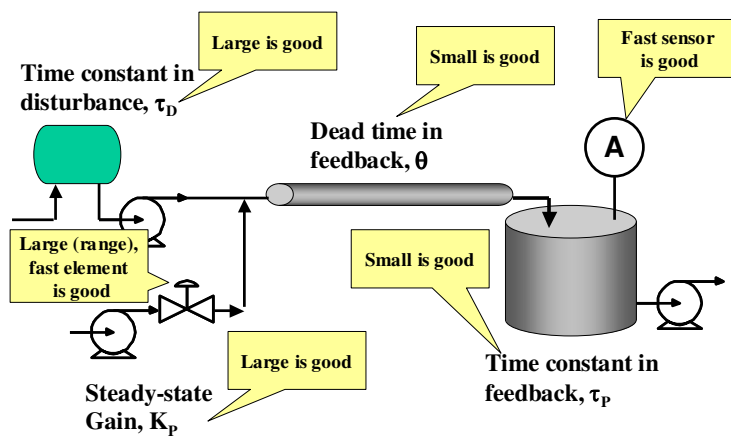

**Figure 15.** Guidelines for good and poor process features for single-loop feedback control.

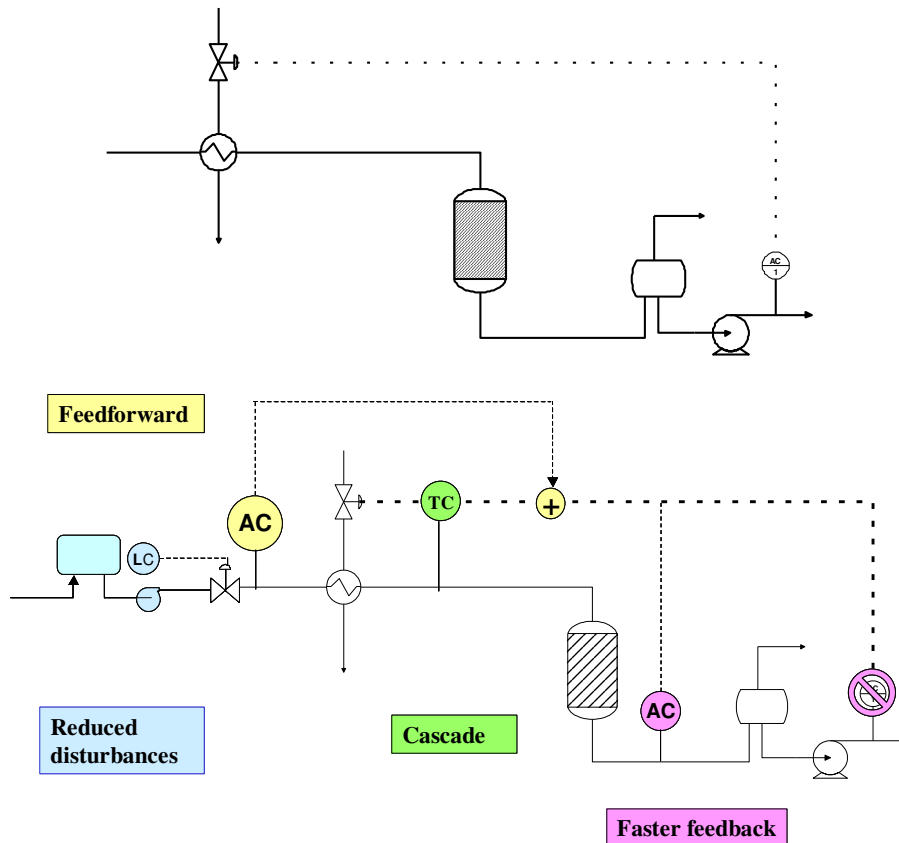

**Figure 16.** A packed-bed chemical reactor with product quality control by adjusting preheat. (a) Basic single-loop feedback, (b) Modifications that could improve performance.

In general, the best performance involves the feedback dynamics that are fast and strong. Note that the “feedback dynamic response” is between the final element and the sensor, and it includes all elements in the loop (except the controller). For the process in Figure 10, fast feedback dynamics are provided through the process design. An automated by-pass around the heat exchangers provides very a very fast response between the by-pass valve and the reactor inlet temperature. Note that adjusting the fuel flow directly would have been possible but would have provided slower feedback dynamics.

In contrast, the disturbance behavior should be “slow and weak”. Naturally, the smallest disturbance gain, i.e., the effect on the controlled variable for a unit change in the disturbance, is desired. Few students recognize the importance of slow disturbances or how they can affect disturbance dynamics via the process. An example is provided for the neutralization process in Figure 17 in which the effluent pH is to be controlled. Every engineer has titrated a strong acid-base solution and understands the challenges involved in achieving a pH of 7. The original design in Figure 17a provides feedback compensation for disturbances, and when the controller has an integral mode, the design will yield zero steady-state offset. However, it typically does not provide good dynamic performance. The modified process and control in Figure 17b provides much better dynamic performance because it contains an additional tank to moderate disturbances, a cascade control, and two control valves. The combination of a large and small control valve enables the feedback controller to achieve the desired total flow rate while having good precision in the small adjustments required for control of the non-linear pH process.

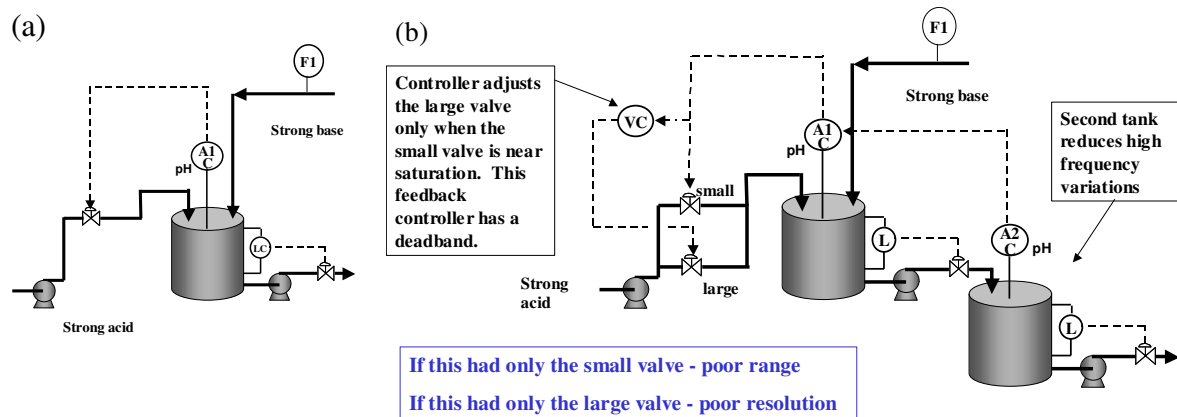

**Figure 17.** Neutralization of a strong acid with a strong base.

(a) Single-loop feedback with single manipulated valve.

(b) Highly operable design including two tanks, cascade control, and two manipulated valves with different capacities (and precisions)

Control technology for multivariable processes involves a vast array of methods, much of which is far beyond reasonable expectations for the single undergraduate course. However, students should be able to propose a multiloop (multiple PID) design that addresses most practical issues. They should initially define the control objectives using the seven categories proposed in the following.

1. Safety
2. Environmental Protection
3. Equipment Protection
4. Smooth Operation
5. Product Quality
6. Profit
7. Monitoring and Diagnosis

Then, they can use guidelines from the instructor and their process insights to design a multiloop strategy. For example, the multiloop design for the simple flash separation process given in Figure 18 conforms to most common control design heuristics and does not require graduate-level analysis methods<sup>26</sup>.

The final design could be evaluated using dynamic simulation, if the process can be simulated using commercial simulators, which is not yet always possible. Good guidelines are available in the literature<sup>27,28</sup>. Other means of evaluating design options is literature from industrial practitioners and from collaboration with consultants who might be willing to collaborate on teaching of the design course.

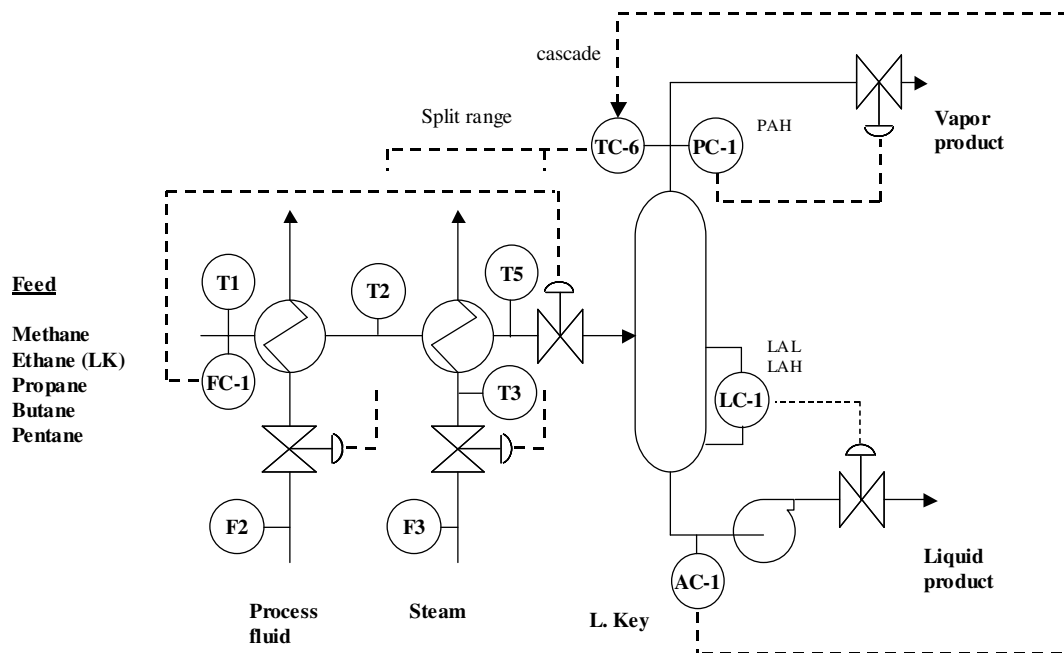

**Figure 18.** Typical control design for a flash separation process.

#### 4.7 Efficiency

The goal of the plant is to earn a profit, and economic analysis using standard methods for time-value-of money, profitability, and sensitivity analysis is part of every design project<sup>29</sup>. After the plant has been constructed, economics remains a high priority issue. The plant equipment cannot be changed, at least in the short term. However, many degrees of freedom exist that enable plant personnel to achieve higher priority objectives (e.g., safety, product quality, production rate) and to influence profit.

Why does this opportunity exist? Because of extra equipment provided for operability. For example,

- The operating window requires some equipment to have greater capacity than required most of the time to achieve desired operation when the “worst-case” situation occurs.
- Flexibility provides many extra control valves, sources, sinks, and by-passes
- Reliability requires multiple equipment, for example, several boilers, rather than one large boiler
- Transient operation like startup requires equipment that is only used for short periods of time or is oversized for most situations.

Since this equipment is available for use, the engineer has the opportunity to select the most efficient combinations and loadings for any specific situation. The proper choice will increase the profitability of the current operation of the process.

When several parallel equipment are in operation for reliability reasons, process efficiency is affected by the selection of equipment placed in service and the relative “load” on each. For example, a single pump can be used at lower product rates, while at higher production rates, two parallel pumps can be used to supply higher flow rates at the same pressure. In another example, the steam demand in a plant can be satisfied by a multitude of loadings of parallel boilers; only one loading has the lowest operating cost because of differences in the efficiencies of the boilers. This situation is shown in Figure 19.

The best utilization of available equipment must respond to the ever-changing conditions in the plant, for example, feed material, production rate and product specifications. When the plant conditions change frequently or the analysis requires complex calculations, the determination and implementation of the best operation should be automated. The automation could be as simple as a controller to minimize the pressure in a distillation tower or as complex as a model of parallel boilers to determine the lowest fuel consumption by allocating the required steam generation among the boilers.

The actions to improve efficiency should not interfere with higher priority goals, such as safety and excellent product quality. In the reactor with feed-effluent exchanger design in Figure 10, we would like to have as little heat as possible provided by (costly) fuel to the heater. In addition, we want operate the plant with the by-pass valve always open to provide very fast feedback control for the reactor inlet temperature. Thus, efficiency is achieved by slowly adjusting the heater outlet temperature (fuel) so that (1) the by-pass valve is open enough to respond to typical disturbances and (2) the fuel flow is small. In this way, tight control and reasonable efficiency are achieved.

Recent advances in computing and optimization methods make it possible to optimize a complex process in “real-time”. The meaning of realtime depends on the process, but for a process that typically operates in steady state, optimization cannot be faster than the time for the process to reach steady state after changes in operation and should not be longer than the time between significant disturbances. For many plants, optimization once every 4 to 8 hours is adequate. The technology uses models that are calibrated to the plant using recent measurements and an optimizer to automatically calculate the best operating conditions for the current situation. An introduction to this technology is available<sup>30</sup>, and optimization hierarchy in a process plant is shown in Figure 20.

$$\text{Efficiency} = \frac{\text{steam flow}(\Delta H_{\text{stm}} - \Delta H_{\text{water}})}{(\text{fuel})(\Delta H_{\text{comb}})}$$

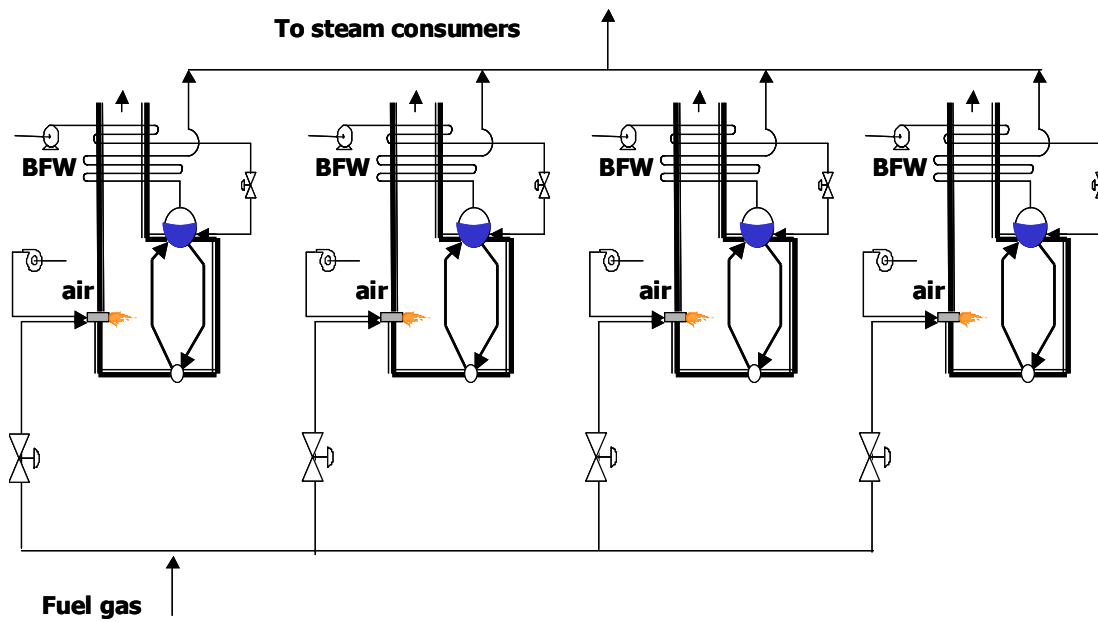
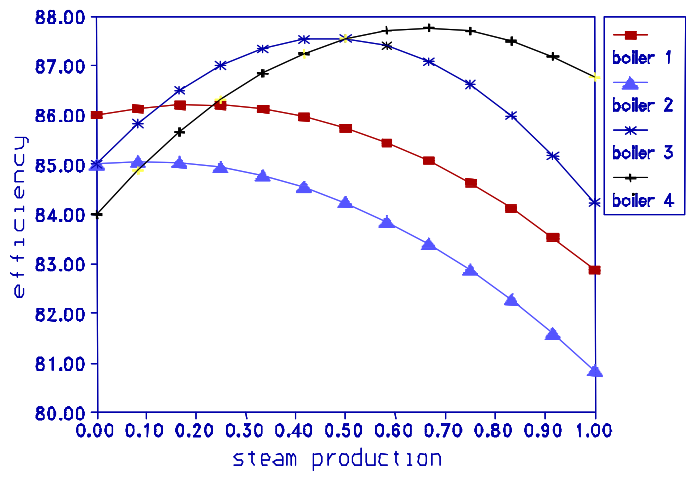

**Figure 19.** The overall unit efficiency can be improved by allocating the generation of steam to the best (optimum) boilers. The optimum allocation changes depending on the steam demand in the plant.

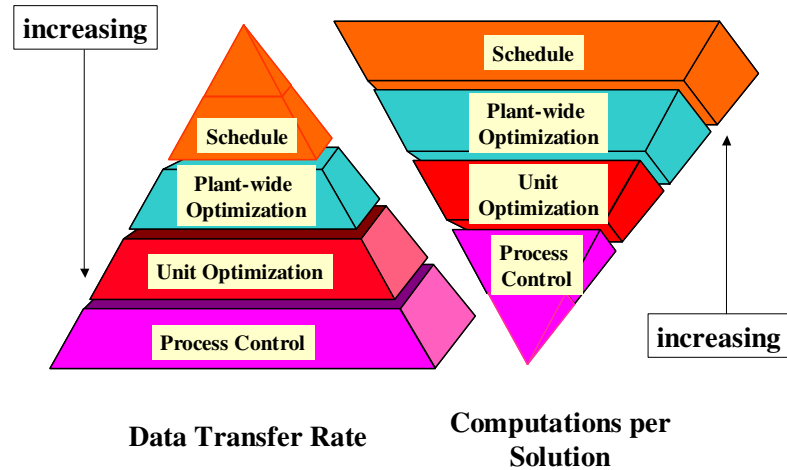

**Figure 20.** Typical optimization hierarchy in a process plant.

Finally, we should recognize all benefits for increased efficiency, in addition to the obvious reduced cost for fuel, electricity, etc. Examples of additional benefits are given in the following.

1. An efficient plant can require smaller capacity, less costly equipment. For example, good batch control with few off-specification production runs can require fewer parallel lines.
2. Reduced energy use can reduce effluents, including  $\text{NO}_x$ ,  $\text{SO}_2$ , and  $\text{CO}_2$ . Environmental protection is taking an increasing important position in international trade and legislation, as highlighted by the Kyoto Protocol (United Nations<sup>31</sup>). Improved efficiencies can mean either (a) reduced emissions at the desired production rate or (b) higher production and profit within the regulated allocation of effluent production.
3. Reduced by-products can reduce the cost for post-manufacturing treatment facilities, such as waste water treatment, electrostatic removal of ash in flue gas, and sulfur recovery.

## 4.8 Monitoring and Diagnosis

Undergraduate education properly places emphasis on control via closed-loop systems. However, we often fail to address many important aspects of plant operation involving open-loop decisions made by plant personnel. Students should recognize the importance of continual monitoring, the types of decisions allocated to people, and the equipment required for analysis and actions.

### 4.8.1 Monitoring and Diagnosis for Rapid Decisions

We start with decisions requiring *rapid analysis and action*, which are typically made by plant operators. These decisions complement the process control systems. While automated control can be very fast and reliable, people have special advantages such as the following.

- They have information not available in the computer from sources such as discussions with other personnel observing the process equipment
- They have the ability to perform small experiments. For example, they can evaluate the effect of changing the controller output value on a flow rate to determine whether the

components between the control signal and the final element (valve) are functioning properly.

- They can perform complex analyses using process principles, e.g., material balances, energy balances, or equilibrium.

In addition, people must monitor the control system for failures in sensors, final elements, or algorithm performance. Generally, there is no such thing as “automatic pilot” for complex plants; to achieve satisfactory safety, reliability and product quality, people are required to monitor, diagnose and intervene.

Students should identify situations in which the process and control system will not provide acceptable behavior. These situations could be due to failure of equipment, such as a sensor, valve, pump, or agitator. When students analyze how a person could identify an unsatisfactory process behavior and diagnose the root cause, they will quickly realize that many sensors are required. Often, a process will have three or more sensors for monitoring for every sensor used for control. For rapid analysis and action, these sensors must be available in a centralized control room, and many could have alarms. An example of multiple temperature sensors to detect hot spots in a packed bed is given in Figure 10b.

The students will also recognize that responses to plant problems should be moderate, i.e., we want repair the root cause while keeping the plant in operation, if possible. The people have extra options for modifying plant operation, for example,

- Changing the opening of manual valves
- Replacing equipment with spare, parallel alternative
- Changing the source or disposition (sink) of a process stream. Alternatives include different tanks, storage for later processing, waste storage, or disposal, e.g., flaring.
- Divert a flow from part of a plant, with the remainder staying in operation

Naturally, a safety interlock system (SIS) would be the extreme response required in some situations. If plant personnel decide that this decisive action is required, they can activate the SIS before the automated system responds.

Research continues on the best methods for interpreting a large number of measurements taken at high frequency. A powerful approach that has found industrial applications involves building statistical correlations among the measurements; when the plant behavior deviates from the typical behavior predicted by the correlations, unusual behavior is identified for analysis by the plant personnel<sup>32</sup>. In addition, research is defining the operating conditions after a problem has been identified; this “safe park” position should be easily and rapidly achieved, provide safe operation with the lowest cost, and allow rapid recovery to normal operation.

#### 4.8.2 Monitoring and Diagnosis for Longer-term Actions

Many more monitoring and diagnosis challenges occur because of longer-term changes in the process. For example, heat exchangers experience fouling, reactor catalyst deactivates, and flow systems can slowly plug. Again, students need to recognize how these types of scenarios are identified and diagnosed. Naturally, sensors are used, but in these cases, many of the sensor

displays might be located locally by the equipment at lower cost. Additional information is provided by laboratory analysis, which provides key information on process performance every few hours or day.

Students should recognize the importance of calculations that assist in diagnosis of large quantities of data, such as calculating heat transfer coefficients in complex heat exchanger networks; these calculations can be performed automatically and reviewed by the engineer on a daily basis. Corrective actions can be scheduled for the least impact on plant operation and can include removing individual equipment (e.g., heat exchanger) for mechanical cleaning or shutting down a section of the process for a short time.

Typical calculated performance metrics for process plants are given in the following.

- Efficiency (e.g., boiler, fired heater, compressor)
- Reactor yields (single-pass, ultimate, after recycles)
- Material balances (in - out at steady-state)
- Separation effectiveness (tray damage, packed bed by-passing)
- Flows indicating lower profit (to flare, to other disposal, steam letdowns, etc.)
- Energy/unit of production
- Approach to limiting values (and violations, if any)
- Time equipment is in use (e.g., pumps, heat exchangers, catalyst)

#### 4.8.3 Trouble-Shooting Method

Using large amounts of information to identify and diagnosis root causes is a challenging task, and students need guidance in building a systematic problem solving approach. Excellent support using examples from chemical engineering is available in the literature<sup>33,34,35</sup>. The approach advocated by Woods has six steps.

1. **Engage** - Review information and talk with people, be confident
2. **Define** - Sketch and define key variables, determine the current and desired states
3. **Explore** - Determine the applicable fundamentals and engineering practice
4. **Diagnose** - Brainstorm possible root causes and prune based on evidence  
- Check evidence for consistency and look for other relevant changes  
- Gather new evidence to eliminate candidates
5. **Implement** - Implement your proposed solution  
- Monitor for expected result; validate your analysis
6. **Lookback** - Prepare steps to prevent a future occurrence of the same root cause

In addition, a highly relevant trouble shooting method is available with many solved problems<sup>36</sup>. Students benefit from experience gained during workshops with debriefing sessions to share experiences and receive guidance and support from the instructor. We must remember that such problem solving is not a component of most university education and that experience using a structured, proven method will improve every student's ability.

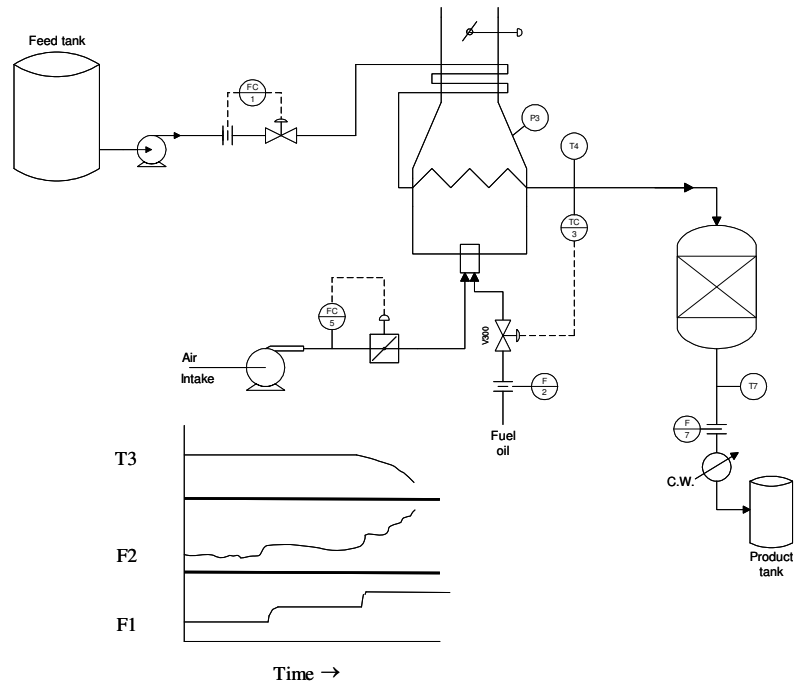

**Figure 21.** The heater and reactor process with recent trend data for a trouble-shooting exercise.

An example of a trouble shooting exercise is given in Marlin and Woods<sup>37</sup> for the process in Figure 21. The fired heater has been functioning properly for many weeks, and recently, the feed rate has been increased. Suddenly, the exit temperature begins to decrease and the fuel to the heater begins to increase, with the rates of both changes accelerating rapidly! The student is in charge of the process and is expected to trouble shoot the situation. Emphasis is placed on applying process fundamentals, qualitative and semi-quantitative (order of magnitude) analysis, seeking additional information in a systematic manner, diagnosing the problem, and proposing corrective actions. Two levels of actions are expected. The first action should solve the immediate root cause and achieve a safe operation in a timely manner. The second action should improve the process design and operation to reduce the likelihood of future problems with the same root cause.

## 5. Course design and delivery

### 5.1 Teaching and Learning Style

The operability topics proposed in this paper can be taught using any appropriate style. Typically, the design course involves a problem-based approach with the instructor providing only general design goals and the students developing solutions under the guidance of the instructor. The level of design detail, from flowsheet to vessel drawings, equipment specifications and P&I drawings varies among instructors and the time provided for the course. However, each operability topic should be addressed in the design and report. When the process flowsheet is large, the students can be allowed to limit the application of selected topics (e.g., all levels of control for safety) to a sub-section of the process.

## 5.2 Process Case Study

Operability is a generic topic of importance to essentially all processes. Perhaps, the only requirement for a case study is the inclusion of several pieces of equipment; for example, the case study would be too limited if only a single reactor or distillation tower were considered. In recent years, the author's class selected their own case studies. Topics of some of these cases are given in the following.

- Ammonia reactor and separation loop
- Milk powder evaporators and fluid bed drier
- Municipal water purification plant
- Desalination plant by reverse osmosis
- Ethanol Production from corn
- Penicillin production (reactor and separation)
- Refrigeration and cooling tower plant
- Boiler feed water treatment and storage
- Boiler and condensate return
- Wine production

The students worked in groups of 4-5 people per group. Nearly every student group arranged at least one plant visit; some had frequent access to a plant and operating personnel. In addition, they researched the process technology. They reported on all aspects of operability in their reports and presented highlights of their studies to the class. These projects were performed in a one-semester course that also addressed engineering economics and was completed before the students began their one-semester design project.

## 6. Experiences and Observations

### 6.1 Students' Experiences

In general, they appreciated the new challenge in applying process fundamentals through qualitative and order-of-magnitude reasoning.

Students especially enjoyed the safety analysis (HAZOP) and the trouble shooting workshops. They appreciated the importance of the goals, especially safety, applied fundamentals in a qualitative manner, and learned from the contributions of their peers.

Importantly, their discussions with plant personnel (operators and engineers) reinforced the importance of operability issues. Also, their plant visits demonstrated that real plants have extensive additional equipment to achieve excellent operability.

The students struggled with the concepts of variability and uncertainty that are inherent in establishing the operating window; they must "unlearn" the tacit assumptions in many previous courses that models and data are exact and conditions (product rate, feed composition, etc.) are static. In addition, they needed time to understand the roles and actions of the plant operating personnel and how they complement the closed-loop control actions. Initially, they also had some difficulty in considering the integrated process; however, they built an understanding as they proceeded through the project.

The students found some useful basic resources in the university library. However, they obtained considerable up-to-date information using the WWW; this experience required them to use judgment concerning the reliability of the source. In addition, some groups contacted industrial practitioners for guidance on process-specific information and for cost information. In summary, the projects would have been limited if the students had been restricted to the use of resources at the university.

Students worked in groups on the projects, which reinforced their organizational, time management and meeting skills. The usual issues rose in apportioning grades fairly to individuals; this issue was addressed through frequent progress meetings with instructors and through a peer evaluation scheme<sup>38</sup>.

One unanticipated outcome was the effects on the students' views of their careers. For example, several students have become interested in the concept of "safety engineering" as a career, and they have requested additional information on the topic and the types of tasks a professional would perform.

## **6.2 Instructor's Experiences**

From an instructional point of view, the course was a heavy load. There were two principal challenges. First, instructional materials are not easily located or, in some cases, accessed. Excellent safety material is available through the AIChE<sup>18</sup> and in selected textbooks<sup>21</sup>. Other topics are covered in various texts and reference books, but no one source provides sufficient coverage of any topic. As a result, the time to prepare an integrated course package was significant. Note that a package of learning materials is essential because the cost for a student to purchase these resources in numerous existing resources would be prohibitive.

The second challenge was the time involved with supporting the students in this self-directed, problem-based course. Many meetings occurred to mentor the groups through the investigation, decision making, report writing and presentation development. However, this is typical for any group-oriented, case-based course, and the instructor could adapt the style and intensity of student-instructor interactions.

Certainly, some industrial experience is helpful, but not essential, when teaching the course. An instructor without such experience would likely benefit from more time for course preparation and perhaps, sharing the teaching with an experienced co-instructor to lessen the load.

Finally, a very mature teaching assistant who can deal with unstructured projects, mentor students during their investigations, and manage the emotional ups and downs of student groups will contribute greatly to the success of the course.

## 7. Suggestions for prior engineering courses

Finally, the learning objectives should address a key deficiency in the preparation of students in prior courses. Nearly all material in the fundamental chemical engineering sciences is presented in a manner intended to solve a design problem. Let's look at a simple fluid flow through a closed conduit in Figure 22. In the typical problem, the flow rate is specified, and the pump power or required pump outlet pressure is determined. Data is available for the "equivalent diameters" or "k-factors" for each item in the flow path. The data typically gives the values for a valve that is 100% open; thus, the solution is for the maximum flow rate. This is a useful exercise completed by all engineering students during their education; so, what is missing? Note that the algebraic expression solved for the flow rate allows all but one variable to be specified and the unknown to be determined. Therefore, the unknown variable could be the pump outlet pressure (or head curve), pipe diameter, flow rate, and so forth.

The typical situation encountered in operating a process involves adjusting the valve opening to achieve a desired flow rate. Usually, this problem is not addressed. We see that the emphasis is on the "design" problem and not the "operations" (or rating) problem. This situation appears to be true for many courses and textbooks in material and energy balances, transport phenomena (momentum, energy and mass transfer), and reaction engineering. While the fundamental principles are identical for both problems, the lack of operations coverage leaves the students unprepared to understand and analyze operating equipment. After all, a plant is designed once and operated daily for many decades, and most engineers will encounter many operations decisions for every design decision.

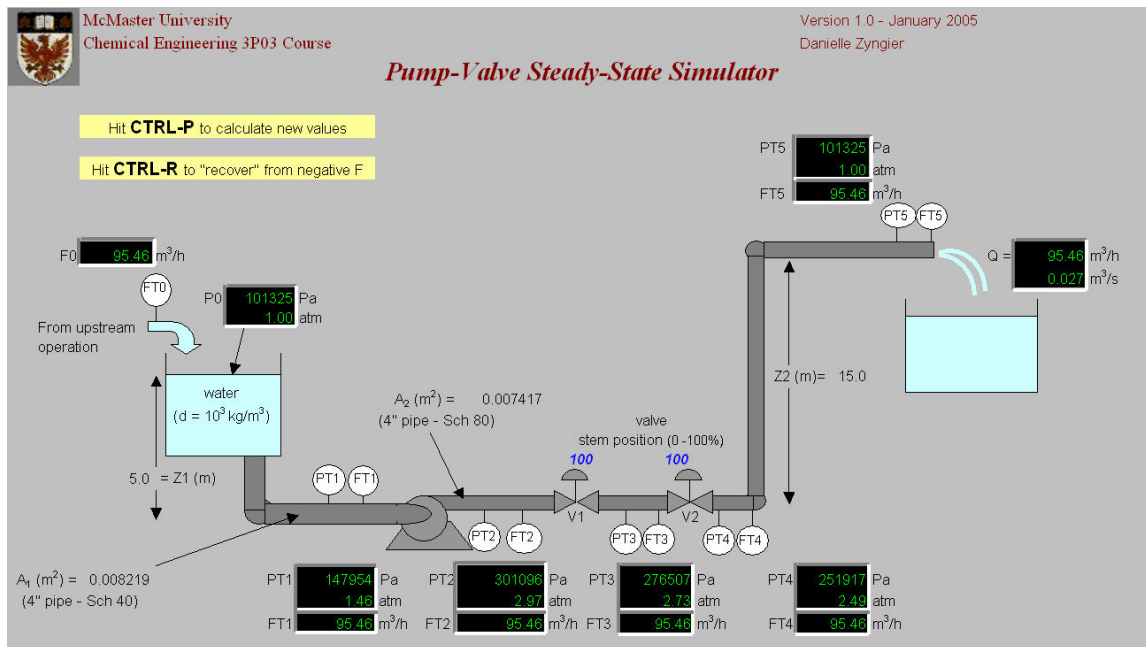

Figure 22. Schematic of pump and flow system.

Therefore, a major improvement in student education can be achieved with a modest modification. We propose that courses begin with the design focus, but expand the applications to operations scenarios. This approach can be achieved in two steps. First, question the achievable range of operations for a given design. Second, specify a range of operations and ask the students to define the equipment that can achieve the specification. To limit the time on a specific problem, students in reaction engineering could simply define the required reactor volume, cooling capacity, and so forth. This proposal provides reinforcement of the fundamental concepts and does not increase the workload for the student or instructor, while providing excellent learning opportunities for the student.

A second key deficiency is the lack of coverage of measurement principles and the associated analysis of measurement errors. Our models deal with variables without regard for whether they can be measured or not, which is reasonable when we build a fundamental model of a physical process. However, the follow-up discussion and analysis of what behavior can be verified with measurements is lacking. For example, at the conclusion of a lesson in mass transfer, students could reasonably conclude that the pressure, temperature and compositions are typically measured on every tray of a distillation column.

When we focus on operation, we naturally consider verifying the achievement of specifications and introduce the selection of variables for measurement. A recommended topic for prior courses involves the selection of key variables for operating a process that has already been defined. After a discussion of the required measurements, the students can select appropriate sensor technology based on the requirements using available resources (e.g., Omega<sup>39</sup>).

## **8. A Proposal for Sharing Resources**

The process systems engineering faculty have taken the lead in teaching design, likely because of the flowsheet innovations in the 1960's through the 80's that facilitated large-scale design calculations. We continue to teach these courses because we have the view of the integrated process and knowledge of process control, alarms, process dynamics and flowsheeting. However, nearly no instructor has a mastery of all operability topics with application to chemical process plants and equipment.

Therefore, the following conclusion is proposed: The teaching community would benefit from a repository of teaching and learning materials on process operability supported by technical references to be used by students in problem-based learning.

How to we proceed? The first step is to establish whether the effort is justified, i.e., whether a critical mass of instructors would introduce some or all of these topics in their courses. If yes, we need to establish the most important resources needed to promote the topic, to encourage instructional excellence without requiring excessive individual effort. After these steps, an organization could be approached to provide the "home" for the resources, which would likely be WWW-based. Finally, experienced instructors and industrial practitioners could offer workshops associated with major national and international conferences to assist instructors.

The author has developed operability lessons with power point visual aids that are available on the WWW for review by other instructors. This material is available at [http://pc-education.mcmaster.ca/operability/operability\\_home.htm](http://pc-education.mcmaster.ca/operability/operability_home.htm)

I encourage readers to contact me to share their thoughts, criticisms and support. In addition, they can propose existing resources for inclusion and note key missing material that, if available, would encourage them to introduce the topics. While the task is daunting, such an effort has been successful for process safety with the creation of SACHE (Safety and Chemical Engineering Education) by the AIChE<sup>19</sup>. Experience indicates that a good topic can find resources.

## **9. Conclusions**

In this paper, an argument has been presented for greater emphasis to be placed on topics related to process operability, which includes decisions on process structure, equipment capacity, and many issues in control and operation. These issues reinforce prior learning and complement the flowsheeting traditionally emphasized in many design courses. Experience demonstrates that operability applies to essentially all process industries and the topics provide an excellent learning experience for upper-level students who have completed the required engineering science and systems courses.

However, challenges remain. A principal challenge is lack of teaching resources, including accessible materials on every topic and solved case studies. A second challenge is the sharing of knowledge among the instructors and support for new instructors. For the operability topic to flourish, a central, easily accessed repository of teaching resources is required. The teaching community is invited to participate in discussing the value the operability topics, the resources required and the management of the resources.

## **Acknowledgement**

I would like to acknowledge the contributions by excellent teaching assistants, Adam Warren, Mark-John Bruwer and Kristen Davies, for their participation in the courses leading to this paper. Don Woods pioneered the problem solving and trouble shooting techniques and problem-based educational approach used extensively in this instruction.

## References

1. Rugarcia, A., R. Felder, D. Woods, and J. Stice (2000). The Future of Engineering Education, *Chem. Engr. Ed.*, 34, 16.
2. CACHE, The Learning Community for Chemical Engineering, (<http://www.che.utexas.edu/cache/>), last accessed July 16, 2005.
3. Valle-Riestra, J.F. (1983). *Project Evaluation in the Process Industries*, McGraw-Hill, New York, pg. 169.
4. Biegler, L., I. Grossmann and A. Westerberg, (1997). *Systematic Methods of Chemical Process Design*, Prentice-Hall, Upper Saddle River, NJ.
5. Sloley, A., (2001). Effectively Control Column Pressure, *CEP*, January, 39-48.
6. Chin, T., (1979). Guide to Distillation Pressure Control Methods, *Hydrocarbon Proc.*, Oct 1979, 145-153.
7. Rosenbrock, H., (1974) *Computer-Aided Control System Design*, Academic Press, New York.
8. Swaney, R. and I. Grossmann, (1985) An Index for Operational Flexibility in Chemical Process Design, Parts I & II, *AIChE Journal*, 31, 621-641.
9. Rooney, W. and Biegler, L. (1999) Incorporating Joint Confidence Regions into Design under Uncertainty, *Comp & Chem Eng.*, 23, 1563-1575.
10. Skogestad, S. and I. Postlethwaite (1996) *Multivariable Feedback Control: Analysis and Design*, Wiley, New York.
11. McAvoy, Y. and R. Braatz (2003) Controllability Limitations for Processes with Large Singular Values, *IEC Res.*, 6155-6165.
12. Perry, R. and Green, D. (1997) *Perry's Chemical Engineers' Handbook*, 7<sup>th</sup> Edition, McGraw-Hill, New York.
13. Wells, G., (1980) *Safety in Process and Plant Design*, Godwin, London.
14. AIChE, (1993b) *Guidelines for Engineering Design and Process Safety*, AIChE, New York.
15. King, R., (1990) *Safety in the Process Industries*, Butterworth-Heinemann, London.
16. Lees, F. (1996). *Loss Prevention in the Process Industries, Volume 1*, Butterworth-Heinemann, Oxford, UK.
17. Herbert, J., Technological Catastrophes, (<http://www4.ncsu.edu/~jherkert/mds322.html>), last accessed July 26, 2005.
18. IChemE, IChemE Safety and Loss Prevention Subject Group, (<http://slp.icheme.org/incidents.html#Flixborough>), last accessed July 27, 2005.
19. AIChE, (2005) *Safety and Chemical Engineering Education Program*, ([www.sache.org](http://www.sache.org)), last accessed on July 26, 2005.
20. AIChE, (1993a). *Guidelines for safe automation of Chemical Processes*, AIChE, New York.
21. Crowl, D. and J. Louvar, (1990). *Chemical Process Safety: Fundamentals with Applications*, Prentice Hall, Englewood Cliffs.
22. Kletz, T. (1986). *HAZOP and HAZAN, Second Edition*, The Institute of Chemical Engineers, Warkwickschire, UK.
23. Wells, G., (1996). *Hazard Identification and Risk Assessment*, Institute of Chemical Engineers, Gulf Publishing, Houston.
24. Seider, W., J. Seader, and D. Lewin (2004). *Product and Process Design Principles 2<sup>nd</sup> Edition*, Wiley, New York.
25. Reklaitis, G., (1995). Computer-Aided Process Design and Operation of Batch Processes, *Chem. Engr. Ed.*, 29, 76-85.
26. Marlin, T. (2000) *Process Control: Designing Processes and Control Systems for Dynamic Performance*, McGraw-Hill, New York.
27. Luyben, W., B. Tyreus, and M. Luyben, (199) *Plantwide Process Control*, McGraw-Hill, New York.
28. Liptak, B., (1999) *Instrument Engineer's Handbook (3<sup>rd</sup> Ed.)*, Vol 2. Process Control, CRC Press, Boca Raton, USA.
29. Blank, L. and A. Tarquin (2002) *Engineering Economy, 5<sup>th</sup> Edition*, McGraw-Hill, New York.
30. Marlin, T. and A. Hrymak, (1996) Real-Time Operations Optimization of Continuous Processes, *Proceed. Chemical Process Control: CPC-V*, Lake Tahoe, Nevada.
31. United Nations (2007) Kyoto Protocol ([http://unfccc.int/kyoto\\_protocol/items/2830.php](http://unfccc.int/kyoto_protocol/items/2830.php)), lasted visited Feb. 3, 2007.
32. Kresta, J., J. MacGregor, and T. Marlin, (1991) Multivariate Statistical Monitoring of Process Operating Performance, *Can. J. Chem. Eng.*, C9, pp. 35-47.

33. Woods, D. (1994). *Problem-Based Learning: How to Gain the Most from PBL*, D.R. Woods, Waterdown, Ontario.
34. Fogler, F.S. and S. LeBlanc (1995) *Strategies for Creative Problem Solving*, Prentice-Hall, Upper Saddle River, NJ.
35. Kepner, C. and B. Tregoe (1965) *The Rational Manager*, McGraw-Hill, New York.
36. Woods, D. (2005) *Trouble Shooting for Process Engineers*, Wiley-VCH, Weinheim.
37. Marlin, T. and D. R. Woods (2002) Trouble Shooting for CAPE Undergraduate Education, ESCAPE 12, The Hague, Netherlands, May 26-29, 2002.
38. Kaufman, D., R. Felder, and H. Fuller, (200) *J. of Eng. Ed.*, April 2000, 133-140.
39. Omega (2007) <http://www.omega.com/>, lasted visited Feb. 3, 2007.

### **A Sample of Chemical Engineering Design Books**

- Biegler, L., I. Grossmann, and A. Westerberg (1997). *Systematic Methods of Chemical Process Design*, Prentice Hall, Upper Saddle River.
- Cameron, I. And R. Raman (2005) *Process Systems Risk Management*, Elsevier
- Douglas, J. (1988) *Conceptual Design of Chemical Processes*, McGraw-Hill, New York.
- Ludwig, E. (2001) *Applied Process Design for Chemical and Petrochemical Plants, Vol I – III*, 3<sup>rd</sup> Edition, Gulf Professional Publishing, Houston.
- Peters, M. and K. Timmerhaus, (1991) *Plant Design and Economics for Chemical Engineers, 4<sup>th</sup> Edition*, McGraw-Hill, New York.
- Rase, H. (1977) *Chemical Reactor Design for Process Plants, Volumes I & II*, J. Wiley & Sons, Inc., New York.
- Seider, W., J. Seader, and D. Lewin (2004). *Product and Process Design Principles 2<sup>nd</sup> Edition*, Wiley, New York.
- Sinnott, R. (1999) *Chemical Engineering Volume 6: Chemical Engineering Design*, Butterworth-Heinemann, Oxford.
- Smith, R. (2005), *Chemical Process Design and Integration*, Wiley, New York.
- Turton, R., R. Bailie, W. Whiting, and J. Shaeiwitz (1998). *Analysis, Synthesis and Design of Chemical Processes*, Prentice Hall, Upper Saddle River.
- Ulrich, G., and P. Vasudevan (2004) *Chemical Engineering Process Design and Economics: A Practical Guide, Second Edition*, Process Publishing, Durham, NH.
- Woods, D., (1995). *Process Design and Engineering Practice*, Prentice Hall, Englewood Cliffs.