

# Postprocessing BEM Results using Sound Power Standards

---

David Herrin  
Aaron Sprowl  
University of Kentucky

---

Vibro-Acoustics Consortium

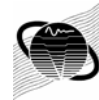

## Presentation Focus

---

### Sound Power Standards

- Measurement in a hemi-anechoic room
- Fixed microphone positions
- Parallelepiped/Hemispherical surfaces

---

Vibro-Acoustics Consortium

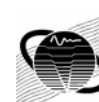

## Commonly Referenced Standards

### Sound Power Standards

- Engineering - ISO 3744:1994 - ANSI S12.34-1988
- Precision - ISO 3745:1977 – ANSI S12.35-1990
- Industry Specific Standards
  - ✓ Earth-Moving Machinery - ISO 6393 (Stationary)
  - ✓ Engines - ISO 6798
  - ✓ Lawnmowers - ISO 11094
  - ✓ Information Technology Equipment - ECMA 74

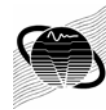

## Characteristic Length of Source

### Sound Power Standards

$$D_0 = \sqrt{(0.5l_1)^2 + (0.5l_2)^2 + l_3^2}$$

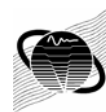
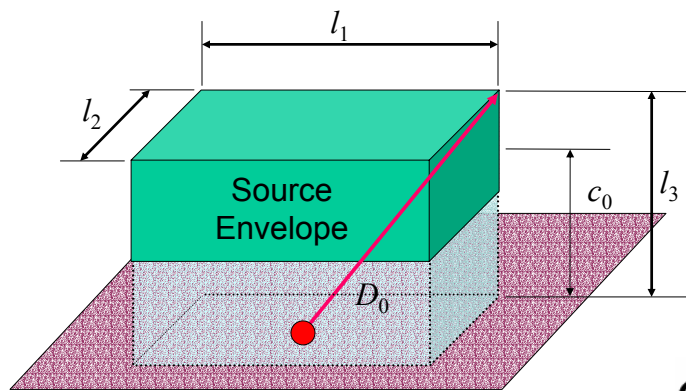

# Engineering vs. Precision

## Sound Power Standards

	Measurement Surfaces	Radius/Distance From Measurement Surface	Minimum Number of Microphones
Engineering ISO-3744 ANSI S12.34	Hemisphere	$2 \cdot D_0$	Hemisphere: 10 Parallelepiped: 9
	Parallelepiped	0.25, 0.5, 1, 2, 4, 8 m	$N > \Delta P_{\max}$ (dB)
Precision ISO-3745 ANSI S12.35	Hemisphere	$2 \cdot D_0$ or $4 \cdot d$	10 $0.5 \cdot N > \Delta P_{\max}$ (dB)
Industry Specific ISO 6393 ISO 11094	Hemisphere	4 m if $l < 1.5$ m 10 m if $l > 1.5$ m	6

Sound power levels obtainable:  
A-weighted and in frequency bands (ISO 3744:1994)

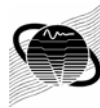

# Parallelepiped Positions

## Sound Power Standards

$$a = \frac{l_1}{2} + d$$

$$b = \frac{l_2}{2} + d$$

$$c = l_3 + d$$

$$h = \frac{c}{2}$$

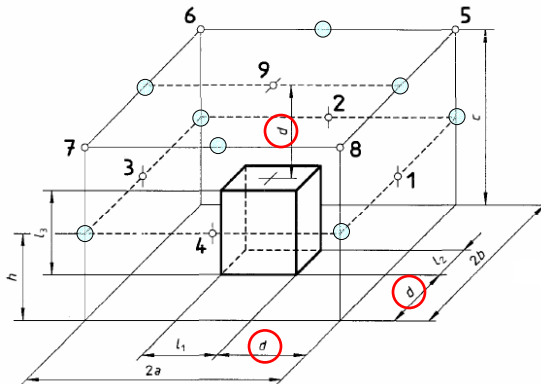

ISO-3744 1994

$$l_1 \leq d$$

$$l_2 \leq d$$

$$l_3 \leq 2d$$

Additional Microphone Positions (ANSI S12.34-1988) ○

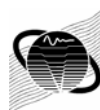

# Hemisphere Positions

## Sound Power Standards

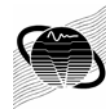
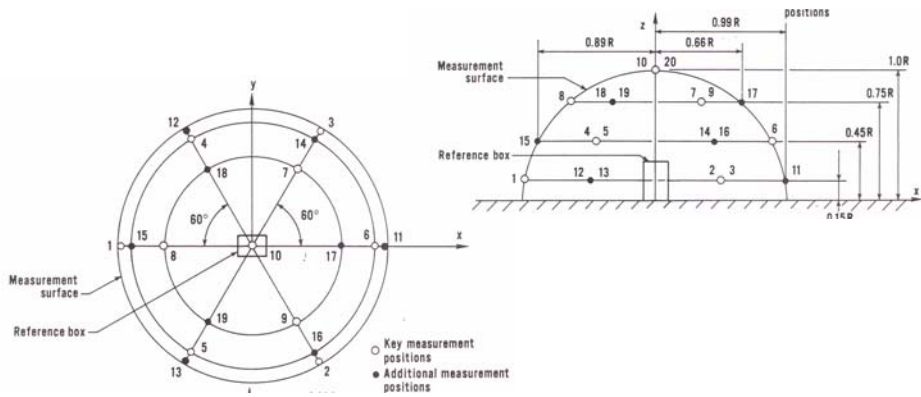

# Industry Specific Hemisphere

## Sound Power Standards

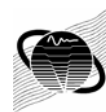
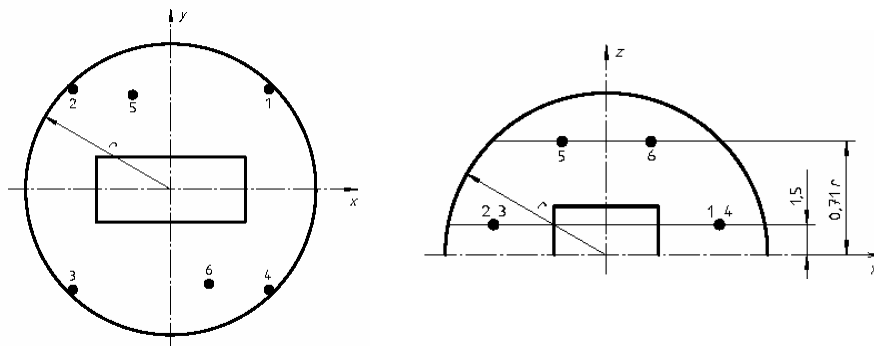

## 3 Test Cases

---

### Sound Power Standards

- Engine

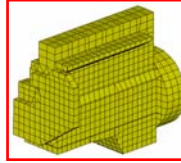

- Transaxle

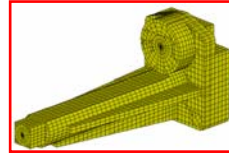

- Construction Cab

